

Guide to Equipment Inspection 2026

GUIDE TO EQUIPMENT INSPECTION

January 2026

PREFACE

This guide is designed to be the standard reference material for equipment inspectors, with the aim of contributing to consistency in measurement all over the world. Parts of this manual are used as textbook for World Sailing International Measurer clinics and seminars.

Since our sport is constantly changing and evolving, a guide such as this has to be a living document that needs to be updated constantly. Therefore, contributions to improve it are always welcome and will be posted on the WS Website as updates are made. The responsibility for the contents of the Guide to Equipment Inspection and keeping it up to date lies with the Equipment Rules Sub Committee (ERSC) of WS.

This guide is based on the International Measurer's Manual. Equipment Inspectors interested in special topics or more detailed presentations should refer to that document instead.

Dimitris Dimou
Chairman
WS Equipment Rules Sub-Committee
January 2026

CONTENTS

Page

A. The BASICS	1
A.1 Introduction	1
A.2 Meaning of Terms	1
B. EQUIPMENT INSPECTION FUNDAMENTALS	4
B.1 "Equipment Inspection and Inspectors"	4
B.1.1 Qualifications of "Inspectors"	4
B.1.2 Appointment and Authority of "Equipment Inspectors"	5
B.1.3 "Measurer's" Practice	5
B.2 Application of Rules	6
B.2.1 Interpreting Class Rules	6
B.3.1 Single Class versus Multi-Class events	7
B.3.2 Inspection Levels	8
B.3.3 Facilities and resources	9
B.4 General Guidelines	10
B.5 Equipment Inspector's Responsibilities	11
B.6 Measurement team Management	13
B.7 Special Items	14
B.7.1 Personal / Portable Equipment	14
B.7.2 Crew weight	15
B.7.2.1 Crew Weight control at events	15
B.7.3 Wet clothing	16
C. MEASUREMENT TOOLS	19
C.1. Standard Measurement Tools	19
C.2. Purpose-designed measurement tools	22
C.3. Special Equipment	24
C.4 Class-specific equipment	23
C.5 Stamps, stickers and forms	23
D. HULL INSPECTION	27
D.1 Hull shape measurement	27
D. 2 Hull weight	27
E. HULL APPENDAGES	35
E.1 Profile	35
E.2 Section	37
E.3 Position	40
E.4 Other controls	41
F. RIGS	42
F.1 Introduction	39
F.2 Spar measurement points and limit marks	46
F.3 Weight	47
F.4. Rigging points	48
F.5. Booms & Poles	48

F.6. Rig Inspection Tables	49
G. SAILS	54
G.1 Sail inspection	54
G.2 Sail inspection Fundamentals	54
G.2.1 Corner measurement points (ERS G.4)	55
G.2.2 Sail edge measurement points (ERS G.5)	57
G.2.3 Primary sail dimensions (ERS G.7)	58
G.2.4 Sail Table Preparation	62
G.3 Inspection techniques	67
G.4 Other Sail Dimensions (ERS G.8)	68
G.5 Identification on Sails	71
G.6 Advertising on Sails	72
G.7 Certification marks on Sails	73
H. MEASUREMENT PROTESTS	74
H.1 Introduction	74
H.2 Right to Protest	74
H.3 Relevant Rules and other Documents	74
H.3.1 RR 60.4	74
H.3.2 RR 78	75
H.3.3 RR 64.3	76
H.3.4 RR 43	77
H.3.5 RR 69 Gross Misconduct	77
I. ACCURACY, PRECISION & REPRODUCIBILITY OF MEASUREMENTS.	78
I.1 Introduction	78
I.2 Basic Standards and Units	78
I.3 Definition of terms	79
I.4 Errors	81
I.5 Measurement Techniques and Reproducibility	83
I.6 Mass and Weight	83

SECTION A. THE BASICS

A.1 Introduction

Racing of all classes of sailing boat under the **Racing Rules for Sailing** (RRS) and **Equipment Rules of Sailing** (ERS) is based on the assumption that each boat complies with its **Class Rules**, the class rules complementing the RRS-ERS by defining the boat and equipment that may be used. Normally it is necessary to measure the physical dimensions of a boat, its equipment and sails to establish if it complies with the class rules and this is the principal role of the **'measurer'**.

Measurers therefore play a fundamental role in the organization of sailboat racing, and their ability to apply the class rules correctly and accurately is essential. Equipment must be measured for **certification** before being used for racing, but it is normally inspected at events as well. Techniques vary in general as **certification** requires derivation of actual dimensions and **inspection** means comparison with known minimum / maximum limits. This is a guide to equipment inspection, giving information firstly on good measurement practice with specific Class examples, and secondly on practical techniques and equipment for taking accurate measurements.

It is essential that measurers always keep in mind that **this is only a guide**, and it also refers to the current class rules of the boats they are measuring. The class rules/regulations override this guide when there is any conflict between them.

A.2 Meaning of Terms

Racing Rules of Sailing (the "rules")

The rules used by sailboats when racing under the jurisdiction of World Sailing.

Class Rules

Set of class specific rules that specify a boat and its use, the crew, personal or any other equipment and its use, and any changes to the rules as permitted by RRS 86.1(c).

World Sailing (WS)

The international body governing the sport of sailboat racing is World Sailing. It comprises member national authorities, class associations, and other affiliated organizations. Among the many WS responsibilities and programmes is the training and certification of International Race Officials such as the International Measurers.

National Authority (MNA)

The national authority is the organization that governs the sport of sailboat racing within its jurisdiction, and is a member of WS as well.

Organizing Authority

The body that plans and runs the races or event is the organizing authority. It may be a club, a class association, a national authority, WS itself, or a combination of any of

these. The Organizing Authority appoints the Race Committee and may appoint a Technical Committee. The Organizing Authority or WS appoints the Protest Committee / International Jury.

Race Committee

The race committee is the committee appointed by the organizing authority to conduct the races. It is responsible for publishing the Sailing Instructions and for scoring.

Protest Committee

The protest committee hears protests, requests for redress and alleged breaches of rule 69. It is appointed by the organizing authority or race committee. It may be independent of the race committee or a subcommittee of the race committee. It may, when meeting the requirements of Appendix N, qualify as an International Jury. From January 2009 International Juries are referred to as Protest Committees when hearing protests and requests for redress.

International Jury

An International Jury is a protest committee that meets the requirements of Appendix N of the rules. It is appointed by the organizing authority and subject to approval by the national authority if required under their Prescriptions. It is completely independent from the Race Committee.

An International Jury is composed of experienced sailors with excellent knowledge of the racing rules and extensive protest committee experience. Its membership is made up of people of different nationalities, the majority of whom shall be WS International Judges. Provided that it conducts itself in accordance with the procedures described in Appendix N, its decisions shall not be subject to appeal.

Equipment Inspector, Technical Committee, Measurement-related Authority

The organizing authority of an event may appoint an event technical committee to inspect boats and check compliance to the measurement rules before the start of the competition, and carry out checks (such as sails set within limit marks, distribution of ballast, weight of clothing etc.) during the competition. An event technical committee has the authority to protest boats for class rules infringements.

If during a hearing the protest committee is in doubt about the meaning of a measurement rule, it shall refer the question, together with the relevant facts, to an authority responsible for interpreting the rule, and is bound by the authority's decision. According to the ERS, Class Rules Authority is the body that provides final approval of the class rules, their changes and class rule interpretations. Class rule interpretation procedures are defined in WS regulations, unless otherwise provided for in the WS-Class agreement. In practice, the authority referred to by the RRS may be specified in the NoR/SI and usually for Class Championships it is a person or a team designated by the respective Class.

Official Measurer, National Measurer, International Measurer.

The term 'measurer' is a term often used to describe a person who performs either certification control or equipment inspection or both. However, it must be made clear that people performing equipment inspection at events should be called "equipment

inspectors”, and those who perform certification control should be called “certification measurers”. The title 'national measurer' is given to a suitably qualified person by a national authority that runs a 'national measurers' scheme and usually refers to certification measurers. The title of 'International Measurer' is awarded by WS to a person who meets the criteria set out in the WS regulations and the relevant documents published by the WS Race Officials Committee.

Race Officer, Principal Race Officer, National Race Officer, International Race Officer.

The race officer is the person in charge of running the sailing race. A principal race officer is a person who is in charge of two or more courses at a regatta. The title “national race officer” is given to a suitably qualified persons by a national authority. The title of “International Race Officer” is awarded by WS to a person who meets the criteria set out in the WS regulations and the relevant documents published by the WS Race Officials Committee.

Judge, National Judge, International Judge

The term 'judge' is a term often used to describe a member of a protest committee who participates in decision making. The title 'national judge' is given to a suitably qualified person by a national authority that runs a 'national judges' scheme. The title of 'International Judge' is awarded by WS to a person who meets the criteria set out in the WS regulations and the relevant documents published by the WS Race Officials Committee.

SECTION B. EQUIPMENT INSPECTION

FUNDAMENTALS

Introduction

Equipment inspection is defined in the ERS as control carried out at an event as required by the notice of race and the sailing instructions. Also known as event inspection or regatta measurement, it is a formal procedure to check compliance with the class rules, ranging from checking certain items only, like the weight of boats or sail measurements, to almost complete measurement of all competing boats. In major events like World or Continental Championships and certainly at the Olympic Games, this task should be done by a team led and managed by one or more International Measurers.

It should be remembered that event inspection is undertaken to check that the boat is class rule compliant in at least some respects and does not guarantee that the boat is complying with every single class rule requirement. Usually a full measurement cannot be undertaken because of the various constraints in time and personnel; however, this in no way relieves the owner or competitor from their responsibility to sail a boat complying with all its class rules. There should be no confusion between event inspection and certification control: in the first case the measurer/inspector is appointed and obtains his authority from the Organizing authority as part of the Technical Committee of the specific event, in the second case the measurer has a contract either with the builder or with the owner of the boat and normally obtains his authority from the MNA of the place where the control is taking place.

Being more of a check than a complete measurement, the actual measurement data usually do not need to be known or recorded, and procedures, such as the use of jigs or templates which reduce the measurement time required can be adopted.

B.1 “Equipment Inspection and Inspectors”

B.1.1 Qualifications of “Inspectors”

The work of an equipment inspector requires technical skills, including the ability to read and understand class rules and to apply them correctly, and the ability to take accurate measurements of length, weight and other physical parameters. Section H describes some techniques for accurate measurement, but it is essential that the inspector operates as prescribed in the Class Rules where details are given.

The inspector must be familiar with the use of standard and some special measurement tools, as detailed in Section C. The ability to make your own special tools is also useful so that a comprehensive tool kit can be assembled to enable quick and efficient measurement/inspection. Some classes provide or sell purpose-designed tool kits for their own class equipment.

One of the best ways for a person to acquire measurement skills is to attend a regatta as a helper assisting the specialized class equipment inspectors. Most classes normally welcome offers of assistance in this area. Some classes and National Authorities run occasional seminars and courses to train measurers/inspectors.

B.1.2 Appointment and Authority of “Equipment Inspectors”

Equipment Inspectors

Equipment inspectors are normally appointed by the regatta organizers and are authorized to conduct equipment inspection checks as required by the organizers. It is acceptable for some event inspectors to be helpers with little or no previous measurement experience provided that they are overseen by experienced class measurers or national measurers.

International Measurers (IMs)

Since 1980 the IYRU (then ISAF and now WS) has acknowledged measurers who have a particularly wide experience and knowledge of the rules and a class by recognizing them as International Measurers. IMs are meant to inspect prototype boats of specific classes and to organize and lead the equipment inspection at international events for those classes. The International Measurers provide a direct line of communication from WS to classes on measurement matters. International Measurers should pass on their experience and train other measurers, thereby leading to an improvement in general standards of measurement. International Measurers have the same authority as Class or National Authority measurers when measuring for certification only if they are also certification measurers appointed or recognized by the MNA of the country where the control takes place or that particular Class. Intimate knowledge of the ERS and of universal practices in measurement /inspection is an important part of IM training provided by WS. In short, IMs form the backbone of their Class technical structure, but in most cases play an important role in their MNA technical structure as well.

B.1.3 “Measurer’s” Practice

A measurer should conduct his work in a professional manner to ensure that sailors have confidence in sailing administration and its officers, and to ensure that he is not open to subsequent criticism or action for failing to correctly follow the rules and procedures. The following points should be remembered:

Integrity

A measurer must be completely impartial. So as to prevent any questioning of his integrity, a measurer is not normally permitted to measure a yacht or its equipment of which he is an owner, designer or builder, or in which he has any personal involvement (e.g. if he is a member of the crew) or financial involvement other than receiving a measurement fee.

Discretion

A measurer should have respect for the feelings of an owner or builder who may have just learnt from the measurer that his boat requires substantial modification before it can be used. However, a measurer must remember that (s)he is checking that boat for the eventual owner who will be bound by all the class rules when racing. The measurer must therefore not allow himself/herself to be swayed by the thought that an item is not

important or that it does not affect the speed of the boat, nor allow any additional tolerances outside those permitted.

Liability

However diligent, it is possible for a measurer to make a mistake, either as a result of misinterpreting the rules or possibly a numeric error. Hopefully, careful study of this manual will help to minimize errors and any error will be minor. However, even a small correction to a boat at a later date can be a costly exercise and an owner may try to claim against the measurer.

To cover for such a possibility it is best if the measurer can have some form of indemnity insurance, and some national authorities and classes operate such a scheme.

Measurer's Reports

If measurement is to achieve its objective of establishing that a boat complies in all respects with the class rules, irrespective of whom or where the boat is measured, it follows that it is essential that the interpretation of all class rules must be uniform. Therefore, if a measurer has any doubts about the legality of any item he should report the matter to the administering authority for advice. Also, as a result of such feedback from the measurers lessons can be learnt and rules can be regularly updated and improved for the future.

A good measurer should report ideas and errors found in rules, remembering that he is part of a team of administrators who are effectively the guardians of the rules.

B.2 Application of Rules

B.2.1 Interpreting Class Rules

There will be occasions when the meaning of a class rule is not clear to the measurer. When measuring for certification the measurer should contact the administering authority for clarification before signing the measurement form, and describe on the measurement form what he has found, so that the administering authority can determine whether a measurement certificate is to be issued or not. For WS Classes, if the administering authority is unable to determine whether the detail is acceptable it will seek an official interpretation from WS or from the International Class Association in the case of a class administered by that body. As with rule changes a measurer should ensure that he will receive all official interpretations as soon as they are received.

B.2.2 Racing Rules and Measurement: Measurer's responsibility - Racing Rule 78.3

This rule lays down the procedure which a measurer is to follow when he finds that a yacht does not comply with the class rules or rating certificate.

The rule reads:

78 COMPLIANCE WITH CLASS RULES; CERTIFICATES

- 78.1 While a boat is *racing*, her owner and any other person in charge shall ensure that the boat is maintained to comply with her class rules and that her measurement or rating certificate, if any, remains valid. In addition, the boat shall also comply at other times specified in the class rules, the notice of race or the sailing instructions. When a *rule* provides that the penalty for a breach of a class rule may be less than disqualification, the same penalty will apply to a breach of this rule.
- 78.2 When a *rule* requires a valid certificate to be produced or its existence verified before a boat *rac*es, and this cannot be done, the boat may *race* provided that the appropriate *committee* receives a statement signed by the person in charge that a valid certificate exists. The boat shall produce the certificate or arrange for its existence to be verified by the appropriate *committee* before the start of the last day of the event, or of the first series, whichever is earlier. The penalty for breaking this rule is disqualification without a hearing from all races of the event.

It is important to note that the measurer has no authority to disqualify a yacht or to rescind its entry.

A measurer is sometimes called upon to report on the circumstances of a protest to a protest committee (or to an International Jury). This report should record only the facts i.e. the measurements or details of the shape of the item concerned and, if requested, the wording of the applicable class rules.

The protest committee may decide the protest after a hearing, if it is satisfied there is no reasonable doubt as to the interpretation or application of the class rules. However, if it is not so satisfied, the protest committee is required to refer the matter to an authority qualified to interpret the matter.

Whichever person or body is consulted, it is important that they are qualified to give a correct interpretation. It is an unfortunate fact that in many cases equipment inspection at a regatta is carried out by someone who is not really familiar with the class, and while competent to measure sails, he may not be familiar with other rules governing the class.

B.3 Equipment Inspection Fundamental issues

A number of factors affect the preparation and planning of equipment inspection at an event. They may be summarized as follows:

- Number of Classes competing, and the size of the fleets
- Desired level of inspections
- Availability of facilities, personnel and resources

B.3.1 Single Class versus Multi-Class events

A single Class event is the most common scenario that an International Measurer will face in his career, and this usually refers to major events such as World or Continental Championships. In such cases, it is possible to concentrate all available resources to perform inspections on as many items as possible and in more depth. Ideally, an International Measurer of the particular Class should be appointed to lead the measurement team. A number of International classes require their chief measurer to be the regatta inspector for their World Championships. Lower level events also fall into this category, but the inspectors may be not be IMs.

Multi-Class events have different requirements in the resources and experience levels of the appointed inspector(s). In this case the available resources have to be allocated such as to fulfil the essential needs of each participating class and may require simplified inspections. Major National events and WS Grade 1 events are prime examples, and at least for the latter, an IM related to one or more of the participating Classes should be appointed to lead the measurement team.

For equipment inspection purposes, Olympic Games and Combined World Championships should be treated as a group of Single-Class events. These events also have a Chief Measurer appointed, but he is an overall manager, depending on Class IMs to lead the individual Class measurement teams. In those cases, the Measurement Committee is also independent of the Race Committee in matters such as class rule infringement reports and subsequent protests.

B.3.2 Inspection Levels

There can be no fixed rule about the required level of inspection at an event. Above all, this depends on both the level of the event –higher level events require more detailed inspections- and the nature of participating Class: measurement-controlled classes require different controls to those for manufacturer-controlled classes. In addition, one can choose to have pre-race or post-race inspections, or both. Certain items such as boat weight are better controlled before racing starts: it is impossible to accurately weigh a wet boat after racing on a cold day and spinnakers are notorious for stretching on heavy air days or if involved in a capsized. On the other hand, “use of equipment” rules and wet clothing rules can be checked after a race without trouble. It must be emphasized that non-compliance during pre-race inspection can be rectified with no penalty, but infringements found in any post-race inspection, which is usually limited to a sample of only a few boats, will lead to disqualification unless there is a discretionary penalty policy in effect. Thus post-race inspection alone has been found to be neither fair nor efficient, as it does not give the competitor the opportunity to correct unforeseen errors in their equipment.

Prior to racing, and in the case of a series this should be taken to mean the first race of the series, an inspector's prime responsibility is to achieve a state where all equipment complies with the rules. In line with this responsibility, if an inspector establishes non-compliance then he should require correction. It is only after an inspector has done this and the defect is not corrected that he should report the matter to the race committee. In other words, prior to racing the inspector should actively endeavour to achieve rule compliance, but be conciliatory, with the interests of the competitors in mind.

After racing has started, an inspector's prime responsibility is to judge compliance as required to do so by the race committee, through the Sailing Instructions, or by the protest committee as a result of a protest. When an inspector is given the authority through Sailing Instructions to undertake spot checks, care should be taken in the choice of the items to be checked.

As a recommendation, there may be 5 levels of inspection as follows, and they may be adapted to suit local conditions, personnel, event specific requirements and the nature of each Class:

LEVEL 1 - (National qualification events)	Only Measurement Certificate and form + Safety equipment
LEVEL 2 - (National Championships)	Measurement Certificate and form + Corrector weights + Sails + Safety equipment
LEVEL 3 - (National Championship of Olympic Classes or International Events)	Measurement Certificate and form +Sails + Weight and Corrector Weights + Safety equipment + Marks on spars
LEVEL 4 - (International Qualifying Events, Continental & World Championships)	Measurement Certificate and form + Sails + Weight + Corrector Weights + Marks on Spars + selected items + Safety equipment
LEVEL 5 - (Olympic Regatta)	Measurement Certificate and form + Almost full Measurement + Safety equipment + Olympic requirements

In addition, at all levels there should be limitation marking of equipment whose replacement during the event is limited and controlled by class rules.

Level 4 inspections are more or less standardized for each Class, and if the appointed inspector is a Class IM, they are more likely to be performed in the same way from one event to the next.

B.3.3 Facilities and resources

The facilities required to undertake a programme of inspections at a championship will depend on the work which is to be carried out. It is very rare that all the facilities needed are available so the measurers will have to adapt their work or methods to take into account what is available.

Wherever possible all measurements should be performed in facilities with a solid floor, under cover and in any case out of the wind. Ideally there should be enough space to do all the controls in one place connected to the boat park and having separate entry and exit points that can be closed to keep wind out. In a hot climate venue, it may be necessary to have an air-conditioning system. Usually, this doesn't apply in cases of large boats, where the only chance for hull inspection may be before they are launched for the event, and the boat inspection can only happen at the launching crane area.

Hull measurement can be carried out in any building with suitable access, or in a large tent. Whatever is used it should have a fairly level floor, particularly if the boats are to be moved. Weighing machines, if of the platform scale type, require a firm foundation. If of the hanging type, they require some overhead structure able to take the loads with a high safety factor.

Sail measurement, ideally should be carried out on tables about 85-90 cm high. These tables have to be specially made to suit the particular class and consequently may not be always available. In addition, for bigger boats it may be impractical or even impossible to make such tables. Therefore sometimes the sails may have to be measured on the floor. If so, the floor should preferably be of wood or some other smooth and dust free surface. The use of a Mylar template for sail inspection has the advantages that it can be quickly rolled out on tables or the floor, provides a clean surface, and consistent sail inspection from regatta to regatta. It is especially useful for mid regatta inspection when measurement facilities have often been disassembled. As a last resort, an empty parking space may be used instead, provided it is not used by cars during the inspection period.

If the inspection programme is to include hull measurement, centre of gravity or weight distribution tests, weighing, rudder and centreboard measurement, spar measurement and sail measurement, it is clearly impractical for all the work to be carried out by only one or two measurers. So, in those cases it is necessary to use non-qualified assistants. This is acceptable, provided the assistants are adequately instructed on how to undertake the measurement, what to expect to find, and to report any discrepancies to a qualified measurer to make any final decisions. Some operations also require the boat to be moved -for instance weighing- and it is very helpful if there are people available to assist with this work. It is essential however that the owner or his representative take full responsibility before a boat is moved or lifted.

The last parameter to take into account is the time actually allocated for regatta inspections: this is always decided in advance and usually before the number of boats to be inspected is known.

From the above, it follows that the actual inspection process is a compromise, based on what is desired and what can be accomplished with the available resources: having less time or fewer assistants than the ideal will inevitably lead to fewer items to inspect, and if there is no space protected from the elements, it will be impossible to measure hull weight accurately and therefore this control, or radius of gyration measurements should not even be attempted.

B.4 General Guidelines

The following is a set of guidelines that may help when preparing and organizing inspections, especially at the higher levels (4 & 5).

Production line method (Measurement stations). Since the time available for measurement is invariably short it may be necessary to adopt a production line method of carrying out the work with one measurer (with enough assistants) running one measurement station where for instance, the hull templates would be applied. The boat is then passed on to the next station and so on. If the boats are being moved from one station to another, the distance which they have to be moved should be kept as short as possible, as this is less tiring for those involved in moving the boat, and results in less time being wasted. A flow from entrance to exit not requiring boats to back up is strongly to be desired. For large fleets it may be possible to have parallel production lines, which may share some stations.

It may also be possible to control some of the items concurrently, but that depends on how the Class rules are written: as an example, if the hull weight is specified, it may be controlled at the same time as the rig or the appendages are checked at their assigned station. But if the boat weight is to be controlled, then one has to wait until these components have been completely checked before putting them back on the hull to measure the boat weight.

Timetable. This depends on the available (allocated) time, the number of participating boats and the desired level of inspection. Many regatta inspectors divide the allocated time into blocks and allocate these to each competitor, others allow the competitors to sign up for the time block they prefer, while a third option, which has the greatest flexibility, is to allow competitors to sign up in an order and to keep them informed about your progress and their position in that order.

Number of Qualified Measurers + assistants. This has to be agreed beforehand with the Organizing Authority (OA) and is obviously related to the level of inspection

desired. Given the fact that inspection may include fundamental measurement, and that this will be inevitable in case a part does not comply with the rules when controlled using go/no go gauges, there must be at least one qualified official measurer.

Special inspection forms using the yes/no system instead of the actual measured values. There may be separate sheets for each item, such as sails, mast, hull, safety equipment etc. with clear identification on each sheet. A binder, with transparent pockets for the sheets for each boat facilitates the organization of the paperwork.

Jigs, templates, measuring rods etc. should be used wherever possible; measurement tapes etc. should be avoided as much as possible because they require trained people to handle them properly, in contrast with a go/no go gauge.

Sail measurement should be performed on tables except when the size of the sails makes that option not practical.

Special equipment should be brought in by the Class or IM (swing test apparatus, hull templates etc.). A variety of scales for hull weight, crew weight, mast weight, tip weight, anchors etc. and corrector weighs are required and are best supplied by the measurer but may be provided by the OA. They must be calibrated on site and of the right span and resolution for their purpose.

Measurer's RIB (when needed for post-race on the water checks) should be requested from the OA in advance.

General plan for the actual inspection process (timetables, items to be inspected, and requirements regarding area, tables and equipment to be provided by the OA etc.) should be developed by each Class for their major events, to ensure uniformity in methods and procedures. A list of these required facilities, equipment and volunteers should be sent to the OA a few months before the event. Several classes have developed excellent guides that may be found in most cases on their websites. One of the tasks an IM is expected to carry out is to check and try alternative methods in order to improve the inspection process for his class, share experiences and knowledge with the other IMs of his class, and make suggestions for improvement in class rules.

In addition to the general guidelines, a person in charge of a multi-class event inspection should consider the following:

"Important" items (so more likely to need checking) vary from one class to another

The advice of each Class Chief Measurer, who is a recognized expert and should be able to offer proper guidance on what to look for, should be taken into consideration when planning the inspection system.

The number of items to inspect depends heavily on available resources: manpower, facilities, current measurement issues of each class and of course the allocated time: In the case of problems, one has to reduce the total number of inspected items, or the number of boats that will be inspected, or the desired level of inspection.

B.5 Equipment Inspector's Responsibilities

Before accepting a measurement committee appointment, a person has to ensure that

- He has no conflict of interest (Col). The WS Race Officials Committee is the body that decides Cols in case of doubt
- He can commit for the whole duration of the event unless otherwise agreed with the event organizers and the other members of the technical committee.

One has to decline the invitation if there is any problem!

Having accepted the appointment, an EI has to:

- Obtain and review the draft versions of the NoR, sailing and measurement instructions, approving and finalizing those parts that affect inspection.
- Contact the relevant Class Chief Measurer, to make sure he has the latest information on the Class inspection procedures, current class rules and all other relevant documents. In addition, one must ensure that one's toolkit includes all the required tools and equipment; it is highly unlikely that all the required items will be found at the venue: chances are that either the quality will be below standard or many things will be missing. It is too late to find this out on arrival.

Normally the OA appoints a measurement coordinator, who should be contacted to be given guidance and instructions for the necessary preparations.

Planning considerations

The number of days allocated for inspection and the number of participating boats gives an indication of the average inspection time per boat. For that, one needs to take into account realistic start and finish times, and also time for lunch breaks.

Slot allocation varies between classes, with systems ranging from open timetables where individual teams can choose the slot they prefer (Finn, 470 etc), to fixed ones that specify exactly the order of inspection. The latter method works well in junior classes like the Optimist, where national teams are managed by a team leader or head coach, and thus complete national teams can be inspected as a group. The team leader or coach is instructed on what to prepare and what to avoid during the inspection of the first boat and then he can go and prepare the rest of the team boats.

Manpower requirements depend on the number of items to be controlled and on the way these controls will be performed during each time slot: items that can be checked in parallel obviously require different teams. As an example, a dinghy class inspection includes sail, rig, appendage and hull inspections. The available time per boat is 10 minutes, so for that time frame all stations should run in parallel. If the same class is to be inspected at the Olympic level, the time slot can be 45 minutes and in that case rig and appendage stations may be run in sequence by the same team, because the hull station will take at least 35-40 minutes to finish hull shape measurement, before requesting the rig and appendages to perform boat weighing. A crucial part of boat weighing is the inspection for extraneous items and water, as well as careful lifting and arranging of the hull (plus rig), so adequate time and volunteers should be assigned to this station.

Normally, a sail station is handled by two persons, one of which should be a trained measurer. The same is true for rig stations, while a dinghy appendage station may be manned by only one person.

The hull station usually handles weight control, but may also include hull shape, weight distribution and appendages (for keelboats), so the number of people varies, but usually there must be at least two persons assigned. In addition, it is highly recommended to have a dedicated secretary to handle and collect all relevant papers (measurement and inspection forms, certificates etc.).

The chief measurer (inspector) should avoid direct involvement with any measurements as much as possible, concentrating instead on controlling the team and checking cases that

require expert judgement. He will also perform all fundamental measurement in cases where equipment fails the go/no go gauge inspection.

It is advisable to use the most experienced local inspector for “pre-inspection” of the boats, to ensure that boats entering the measurement area are ready for inspection: hulls and equipment dry and with no extra items, all papers present and in order, various parts of equipment in the as required condition (e.g. sails out of spars, appendages separated from hull etc.). This operation is critical in avoiding unnecessary delays when boats arrive in an unprepared state.

At the Venue

An event chief measurer (inspector) should always plan to arrive early, having at least one day set for preparations before the first day of inspections. This is absolutely necessary when doing level 4 or 5 inspections.

Once there, he should:

- Meet the local measurer/coordinator as soon as possible.
- Ensure that the facilities and equipment the OA provides are what he had requested. Finalize the arrangement of the measurement stations in the best possible way.
- Unpack all equipment and start preparing the tables, templates etc. Check that the scales are working and that they are certified and calibrated.
- Check that the sail stamp and ink, and the equipment stickers are of proper quality.
- Visit the club offices, checking that they have printed the required forms and other documents. He should also check that there is a measurement notice board very close to the inspection area, for all relevant information to competitors including the inspection timetable.
- The assistants should receive their station assignments and specific instructions on their job early enough to allow actual training before the end of the day.
- To train the assistants, one or more of the local team boats should be taken through the inspection process.

B.6 Measurement team Management

Unlike Juries, Measurement teams almost always include people with little or no measurement /inspection experience. To manage the team properly, the chief inspector/measurer must always keep that in mind: specifically, he must be patient, and explain clearly what he wants from them; he must let them understand that he is the only authority in the team, and that he calls the shots.

In addition, the chief inspector/measurer should allocate the team members to each station: to do that efficiently he should ask about their preferences, but also consider their individual abilities / experience. For example sail, spar and hull weight stations are each manned by two persons, so he should take care to combine one experienced member with another of less experience, but not to put two members of low experience together.

Unlike Judges and Race Officers, Inspectors are in direct contact with all competitors and their coaches. In all cases, the whole measurement team should be friendly, fair and impartial (this includes giving the right appearance, when for example competitors from the local Clubs are to be inspected by assistants who may be their friends).

The chief measurer should be willing to answer any questions and certainly to explain his decisions. Especially when dealing with “difficult” competitors or coaches, he should be patient but firm, avoiding arguments and personal confrontations; the object is to keep calm, civil, be prepared and explain as best as he can. It is very important to show that the chief measurer knows his job and the rules and that he only wants to provide a level playing field.

On the water, the Measurer’s boat should be visible, always staying close to the fleet before the start and between races: a competitor may need to show damaged equipment to get authorization for replacement. All moves of the boat should be planned ahead, avoiding at all costs competing boats. At the finish, it is vital to pick a spot that will give easy access to finished boats without obstructing the RC or Media boats. An inspector should not interact with any competitors unless he is actually inspecting their boat, or requested to assist as a rescue boat. As in the case of Judges, there should be two inspectors on each measurer’s boat, so that there is always a witness and a driver to control the powerboat while one inspector is checking things inside a competitor’s boat.

Finally a chief measurer should be keeping notes for further analysis: when something goes wrong, one has to find the reasons behind that, before reaching a solution for next time. If a particular class rule is not clear or not easy to apply, or a new development in equipment exploits the rules, then the class authority must be informed.

B.7 Special Items

B.7.1 Personal / Portable Equipment

Personal Flotation Devices

Sailing instructions usually state that wet suits will not be considered to be adequate personal buoyancy and therefore competitors have to have approved Personal flotation devices (PFDs).

Requirements and standards vary from one country to another and therefore it is not possible to give firm statements on what may be accepted. However, if personal buoyancy is required then it must be an item of equipment which has been made as a Personal flotation device. Personal buoyancy shall comply with the specific class rules. Where not specified in class rules, personal buoyancy compliance with ISO 12402-5 (level 50) which has replaced EN 393, or any other equivalent standard may be accepted. Inflatable buoyancy aids are not permitted if the Class Rules specify that.

The equipment inspector should not accept a PFD if it is damaged, or modified in any way which can affect its performance, or which would allow it to come off the wearer, or move, thus reducing its effectiveness. In any case, an equipment inspector should not improvise trying to “test” a PFD. There are specific tests (ISO 12402-9) that are beyond the scope of an event inspection, therefore the inspector should limit himself to checking the label/markings and visual inspection for modifications by the owner.

Trapeze Harness

There are often two requirements for a trapeze harness or hiking aid: maximum weight and positive buoyancy in fresh water.

Ballasting the harness with lead or other material in order to bring it up to the maximum weight is not permitted by RRS 50. To check for positive buoyancy the harness should be fully immersed in fresh water so all air pockets are eliminated and the harness material soaks water. As no time for floating is specified it is sometimes asked how long the harness shall be able to float. The requirement is that it shall not sink when fully soaked. When checking the harness weight, it is important to soak it fully in fresh water or to use a hose to the same effect, and then to hang the harness from the scale in a way that allows it to drain in the fastest possible way. If a harness is tested heavier than the weight limit, the sailor can always try another time by arranging the harness in the way he prefers.

Bow Numbers and sponsor advertising

In the event that the OA requires bow numbers and regatta sponsor advertising, the OA often requests the measurement team to supervise the placement of these items on the bow of the boat. It is useful to have rags/paper towels and acetone for removing wax, and a template (easily made of cardboard) for placement of the bow numbers and sponsor advertisements.

B.7.2 Crew weight

B.7.2.1 Crew Weight control at events

The following are recommended at regattas where crew weight control is part of regatta inspection:

Many class rules do not specify the procedure for implementation of their crew weight rules and therefore the first duty of a regatta inspector is to contact the class and organizing authority and negotiate an agreed procedure, which should then be announced in the NoR and SIs. The NoR should clearly specify the place and time period(s) for crews to present themselves for weighing as well as when and when competitors are liable for weight checks. Crew weight protest procedures should also be prescribed.

The only crew weighing procedures that provide reliable adherence to the rule are; a daily weigh in before racing (much preferable), or random weighing of crews as they step ashore after a day's racing (less desirable because it forces crews to skip drinking water which may lead to dehydration). No negotiation, simple exclusion. Soft rule enforcement leads to bad events and bad feeling among competitors.

The ultimate choice of procedure needs to reflect the attitude of the class and the nature of the event.

For those classes which allow only one weighing, it is recommended that all competitors should be weighed mid event rather than at registration. This limits any dieting and at least ensures that all competitors meet the weight limit on that day. Procedures for any further checking should be agreed with the event organizers and posted on the official notice board.

The possibility of giving any crew that wishes to, the opportunity to weigh in the morning prior to racing and thus protecting them against protest for that day should be considered.

It is common practice to use inexpensive “bathroom” scales for weighing crews, and this is only acceptable if the calibration has been checked, the resolution step is not more than 100 g, and a standard weight of typically 70-80 kg is available to confirm the calibration and reproducibility on a daily basis. For calibration inexpensive 20 kg bar bell weights can be obtained at most fitness centers but must be first weighed using a certified scale.

B.7.3 Wet clothing

The wet clothing control, which is implemented after racing, (in according to RRS appendix H) should (even if carried out using the same facilities and by the same measurement team) be a completely separate procedure from the crew weight control. It should not produce any evidence on which a crew weight protest could be launched. The selection of crews for post-race wet clothing check should be totally independent of that for pre-race crew weight check, even if this sometimes leads to the same crew being selected for both checks.

Points to bear in mind are similar to those for crew weight with the following added:

- It is vitally important to follow selected competitors in from the race course to ensure that they do not jettison or exchange clothing.
- Wet clothing controls, which take place after racing, can lead to disqualification. It is therefore essential that the weighing is accurate and precise.
- The scale should be water resistant and have a separate display so the results can be kept confidential.
- It is strongly recommended that a certified 10 kg weight is available to confirm the accuracy of the scale, either daily before weighing and/or after a weighing that may lead to a protest. Such confirmation of the accuracy is essential for the jury.
- The procedures to be used for wet clothing control are specified in Appendix H and should be precisely implemented.
- The competitor is allowed to arrange the clothing on the rack but it is recommended that only the measurer is allowed to subsequently ensure correct draining.
- A stop watch is sufficient to time the 60 s draining period but the lifting tackle should be such that the clothing can be rapidly lifted at the start.
- The scale should be continuously read so that the weight at 60 s can be precisely recorded.

B.7.4 Repairs and Replacements of damaged or lost equipment

Equipment that is broken or damaged may be repaired. Class rules should specify if repairs/replacements are permitted and the event equipment regulations or sailing instructions should specify the procedures and protocols for those actions during the event.

If the repair is not possible because of the extent of damage or because the item was lost at sea, or not possible because of time constraints before the next race, the event technical committee may authorize the replacement of that part, either permanently (in the first and second cases) or until the repair can be completed (in the latter case). Once the original item has been repaired, it shall be taken back in the boat and the temporary replacement

shall be withdrawn.

The damage should be accidental or by normal wear and tear. Equipment that has been damaged on purpose by the sailor should not be replaced and the matter referred to the protest committee. The same applies if the sailor has attempted to extend and worsen the original damage. The repair shall not be used to modify the shape, materials or structural properties of the original item. In all cases written permission by the event measurer is required. Special equipment repair / replacement request forms should be created for that purpose.

The new part should be certified (if applicable) and event-measured (if necessary), before the replacement can be authorized by the measurer. This may happen after the race, if the replacement has to take part in between races at sea. Either the measurer or one of the other committees must be notified in such a case. If the replacement part is measured after the race and found to be non-compliant then the measurer shall protest. The original part, if replaced, shall have its event limitation mark (if applicable) removed or destroyed, and the replacement marked accordingly with a new mark.

Certain replacement parts may affect other measurements (i.e. the mast weight by new trapeze lines or the boat weight by a new centreboard). The event measurer should take this into consideration when authorising replacements, and should re-inspect all other parts or combinations of parts which may be affected by the replacement.

Sometimes even relatively small damage is impossible to repair without taking the part to a sailmaker or boatbuilder. That will affect the decision of the measurer about a repair or replacement authorization. A small cut on a spinnaker may be repaired with a piece of self adhesive sail tape but if the spinnaker is made of silicon coated ply, the same cut needs a repair by a sailmaker with a stitched patch. A cut near a relatively flat sail edge (Figures B.7.4.1 and B.7.4.3) may be fixed more easily than a similar cut inside the body of the sail where the shape is not as flat (Figure B.7.4.2). In other cases, there may be no catastrophic damage in place yet but there is sign of imminent failure: a bent spinnaker pole where the spar has signs of imminent buckling (e.g. spar has started to form creases or there is a visible dent) or a cracked rudder shall be replaced, since the failure will certainly occur in the next high-load situation. And repair in such a case is not possible because the spar cannot be pulled back to original shape, or the rudder will need to be serviced by a professional technician.

Replacement/substitution of an item between the event inspection period and the first race should be permitted since the original item has not been used for racing yet.

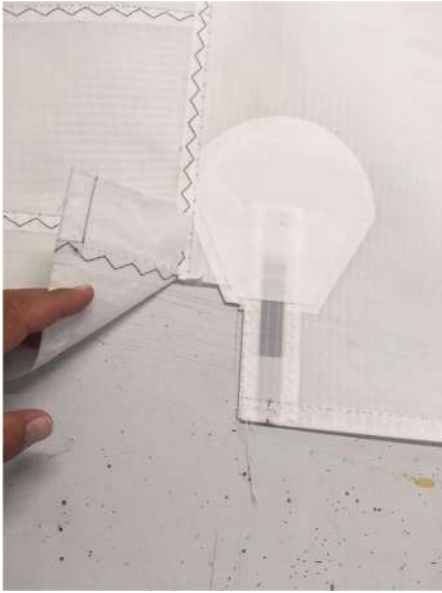

Figure B.7.4.1



Figure B.7.4.2



Figure B.7.4.3

SECTION C. MEASUREMENT TOOLS

C.1. Standard Measurement Tools

The following items of equipment are needed for measuring or inspecting most boats. For inspection purposes, the tools are needed either to measure directly pieces of equipment or to create the inspection tables / templates / go-no go gauges.

Most classes use the metric system of measurement so equipment should be calibrated in metric, but some classes still use imperial units so dual calibration may be helpful.

Tape Measure

Must be of steel (preferably with offset zero), as fabric tapes can be very unreliable. 15 m and 5 m tapes are

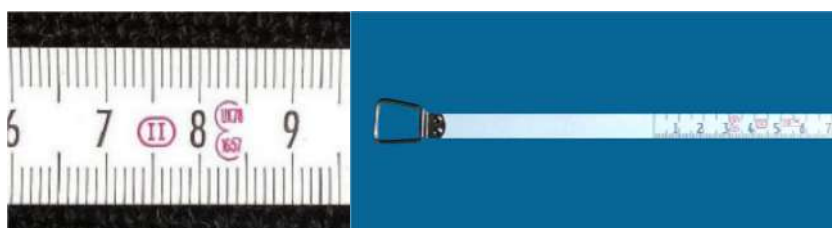

practical sizes for most classes, although for large yachts a longer tape measure is needed. Class II metric tapes are of an acceptable level for normal measurement.

Steel Ruler

One, either 150 mm or 300 mm long is usually sufficient. Articulated or folding rulers if not officially certified are not always accurate and are not recommended.



Straight edge

One straight edge about 2 m long is normally required. Steel or aluminium channel or angle is the most satisfactory. A shorter straight edge may also be required for some work. Some of them are combined with a spirit level, while laser straight line pointers have also become readily available and are quite useful for certain applications.

Spirit Levels

Preferably not less than 500 mm long, having both horizontal and vertical "bubbles". The sensitivity, and hence the accuracy, of some cheap spirit levels is not very great and these should be avoided. Electronic levels with digital readouts are available, but should be sensitive to at least 0.1 degree. Some spirit levels have an additional laser beam and can





be used to make a baseline.

Plumb bob

A plumb bob and line may be required in order to establish a vertical line or to transfer a position to a point vertically below it. A heavy plumb bob with thin line is less likely to be affected by a slight movement of air when measuring in the open. The swing of the plumb bob may be dampened by suspending it in a bucket of water.



Set and/or laser Squares

Two tri-squares are normally required, an ordinary carpenter's square having arms not less than 150 mm long, and a larger one with arms about 600 mm long.

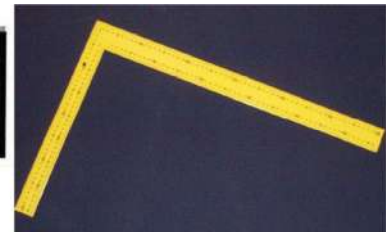

Laser squares are also available in various forms (2 and 3 axis shown here).



Callipers

Vernier callipers are used for measuring items such as the diameters of wire, the thickness of small parts or the cross section of spars. Inside or outside compasses may help to transfer figures where you cannot reach with a calliper.



Scales

The size of the equipment needed will depend on the work that is to be done. Weighing machines need to be regularly checked for accuracy - at least annually - and carefully stored and transported. It is important that the scale has adequate capacity of at least 20% more than is needed. Weighing equipment should meet the



requirements of OIML Class III in EU or equivalent standards in other parts of the World.

One should keep in mind however that the accuracy of an electronic scale is a % of the maximum weight allowed (to take a 2000 kg scale to weigh a dinghy is a nonsense).

Electronic scales with digital readouts are ideal but should always be calibrated before use. For weighing dinghies a steelyard beam scale is accurate but a spring scale is normally satisfactory. For weighing keel boats, load cells are very accurate, but should be calibrated (twist problems). Alternatively dial reading beam scales can be used.



Whatever machine is used it should be calibrated i.e. the readings noted when known weights are added. It is particularly important that this is done over the range of the instrument which is to be used. See also section I of this guide.



Micrometre

Micrometres for sail ply thickness measurement shall have the following characteristics:

- Ratchet stop
- Measuring surfaces diameter as specified in **class rules** or, as a default, of 6.5 mm
- 400gf – 600gf applied to the measuring area
- Throat depth of approximately 21mm minimum
- Graduations to 0.001mm (0.00005in)
- Overall accuracy of plus or minus 0.002mm
- Flatness of anvil and spindle tips: 0.0006096mm or better or a parallelism of anvil and spindle tips: 0.00124mm or better
- Spindle lock



A set of standard feeler gauges are also required when checking sail ply thickness.

C.2. Purpose-designed measurement tools

The following items of equipment are useful for measurement in a wide range of classes and may be produced from simple materials using only basic tools. Some classes offer packs of tools for the class produced by a builder to proven designs and occasionally run measurement seminars to demonstrate their use.

Sheerline Jigs

A means of accurately determining the positions of the sheerline by transferring the line of the topsides to the top surface of the deck is often required. For boats with straight or nearly straight topsides, such as most hard chine boats, a 'C' template (on the left) is adequate. If there is considerable curvature then the sheerline jig shown on the right is better. This jig adjusts to the curvature of the hull and projects the curve up to the sheerline. However, it should be noted that this device assumes the topsides to be a circular curve, and if it is not then an error will occur. To overcome this point in one-design classes with curved topsides C-templates can be made for each measurement station using the lines plan, or preferably full size sections of the hull.



Go-No go Gauges

Examples of purpose-made measurement tools would be tools like a "go-no go" gauge for measuring a spar section or a transparent template to check sail numbers.

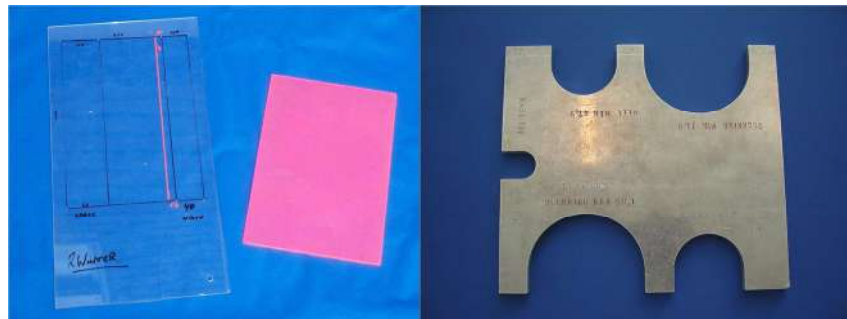

Water tube

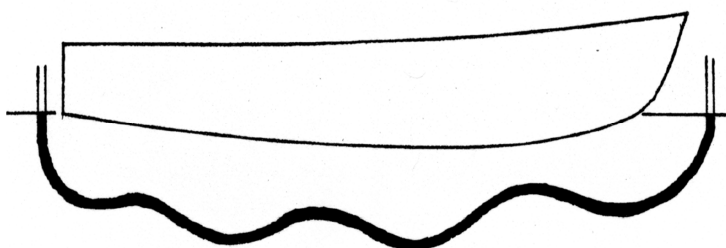

Measurement of boats on uneven or sloping ground requires a means of transferring a level from one end of the boat to the other. Although a surveyor's level can be used, a cheap and simple alternative is a flexible tube filled with water. The tube must not have any 'air locks' in it and the internal diameter of the tubes should be at least 8 mm. The smaller the tube the more rounded the top of the water will be, which is our reference plane, and the more difficult it gets to take accurate readings. The length of the tube required of course depends on the length of the boat to be measured. About six metres is required for a boat 4.70 metre in length, but for a larger boat additional length would be needed to allow for the increased depth of the hull as well as its longer length. For ease of use it may be desirable to use a reservoir of water and to have the tube in two pieces.

Manometers

A simple manometer or a similar device with a digital pressure meter may be used to test the airtightness of buoyancy tanks.

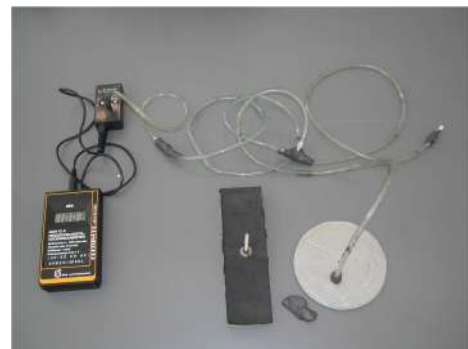
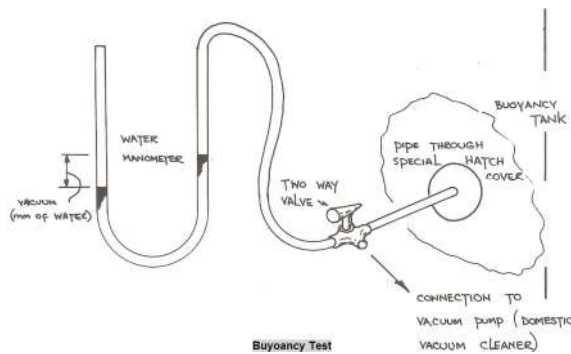

Hull Baseline systems

Beam baseline systems are easy to use in dinghy hull measurement and an affordable alternative to specialized jigs. They can be crude or highly elaborate depending on personal taste and the desired level of flexibility: the system shown below may be adapted to suit a number of different classes in a matter of minutes using sets of interchangeable fittings. In addition, car jacks are useful in setting up



the hull on the desired trim (hydraulic jacks for bigger boats).

Stop watch

Electronic stopwatch: 1/100 sec resolution.

Electronic timer with photo gate (quartz crystal, not RC), resolution 1/10000 sec



Surveyor's Level

When setting up a large keelboat of, say, one of the metre classes, it may be more convenient to use a surveyor's level or a theodolite (below left) although a water tube can be used. A laser beam level (below centre) is also suitable if a great accuracy is not needed. For smaller boats, a self-levelling laser (below right)



may be used to draw a continuous virtual "baseline" or to set a horizontal reference line.

C.3. Special Equipment

Coating thickness measurement

To control the shape of the keel, some classes require checking the thickness of the coating. There are mainly two typical non-destructive ways to achieve this control:

- Magnetic based instruments, but they work only on steel keels (Elcometer tool shown)
- Ultrasonic velocity based instruments; they work on any materials (Panametrics-NTD – Model 25 DL PLUS shown).



This precision microprocessor-based instrument uses pulse-echo techniques to measure material thickness. It can be linked to a computer (RS-232 communications port).

Fiberscope

A tool like the Olympus fiberscope is a useful although high-end piece of equipment that allows the inspection of confined spaces like hull buoyancy tanks or the inside of a mast spar from an external location. It consists of:

- a light source, typically a 150 watt tungsten lamp
- a fibre optic cable to convey the light to the point of inspection
- another fibre optic cable to return the reflected light from the object of inspection to the view finder
- a viewing piece with focusing elements



Also incorporated in the viewing piece are four way angulation's controls that allow the steering of the inspection end of the fibre optic cable. A 50mm length at the end of the fibre optic cable can be steered to allow viewing over a hemispherical arc and with an appropriate camera photographs of the object under inspection can be taken as well.

More affordable equipment is becoming easier to get these days, like the compact inspection camera shown to the right: incorporating a LED light and the capability to send the image to an external monitor, tools like this or simple fiber optic cables connecting through USB to smartphones are more than adequate for sailing equipment measurement and inspection purposes.



3D-Scanners

In 2023 World Sailing invested in new technology to help perform equipment inspections. The 3D Scanner has been used successfully to evaluate production tolerances of hydrofoil manufacturers for Olympic Classes such as iQFOiL, IKA Formula Kite and Nacra 17. The 3D Scanner was also used during the 2024 Olympic Games to inspect the iQFOiL Class and the Nacra 17 Class, the use of the technology had a pivotal role in ensuring level playing field across the Olympic fleets.

C.4. Class-Specific Equipment

Some classes have developed special jigs for hull measurement, which are used mostly at major events, but similar systems are sometimes set-up in builders' premises for normal measurement of production hulls. In other cases, a hollow hull template made from the master plug may be used to check the rule compliance of the hull. The hull template can be easily fitted to the inverted hull and a visual inspection can be undertaken in a very short time. These systems tend to be bulky and expensive.



C.5. Stamps Stickers (event limitation marks) and Forms

Accurate records, namely complete sets of regatta control forms for each boat, with identification numbers for each piece of equipment are essential, and teams should not be allowed to leave the measurement area without signing their form that all regatta stamps and stickers are in place on their equipment. This is essential proof if a boat is later found with equipment with no sticker.



SECTION D. HULL INSPECTION

D.1 Hull Shape Measurement

D.1.1 Introduction

Hull shape measurement is the procedure to get certain dimensions of a hull's external surface, and finally compare the hull shape with the original as-designed shape. The latter may require the use of special templates which outline the "standard" shape of a particular "section" of the hull, or –in case the hull shape permits, as in chine hulls- may be accomplished with direct comparison to a set of XYZ offsets.

Measurements usually include hull length, width (beam) measurements between certain points, keel profile shape (rocker), bow and transom profiles and of course the external shape of the hull in specific sections (stations or "frames"). In addition, class rules may specify other construction details such as internal or external radii at corners, edges, gunwales etc.

The same principles apply both when measuring for certification and inspecting at events. At the latter, time is a major factor in determining the methods and special jigs are usually the tools of choice.

D.1.2 Reference Systems

To measure a hull, one needs a Hull Datum Point which is the starting point for taking measurements from, and a Cartesian axis system to define the major axes: longitudinal, vertical and transverse. These are related to a "baseline" defined in the Class Rules (usually an imaginary line parallel to the designed waterline) and the hull centerplate (hull in Measurement trim). Once the reference system is defined and in place, measurement "stations" can be defined as transverse sections "cut" through the hull at certain longitudinal positions according to class rules.

D.1.3 Hull Profile

The hull profile on the centreline, sometimes called the keel rocker or hull rocker, is normally measured perpendicular to the base line. If the base line is set up horizontally, then all depth measurements can be taken vertically.

There are many ways in which the base line can be supported, but whatever method is adopted it has to be such that the base line is accurately and strongly supported, and that the sag of the line is very small. Some measurers claim that the only satisfactory equipment to use is a beam. However, beams also sag and if of wood may warp. Stiff aluminium beam sections should always be used with the large dimension vertical (Figure D.4.3) and then yield acceptable results, having maximum vertical deflections at mid-span of typically less than 1 mm, which again may be checked on the spot with laser lines/levels.



Figure D.1.3.1 *Beam Baseline*

The hull has to be supported in such a way that it is not twisted and does not sag or hog. This is especially important for keel boats for which the keel should be supported. Whatever method is used to support a hull it is advisable, if the hull is a long one, to place the supports to minimize any deflection of the hull. This can be achieved by putting the supports about one-quarter of the length of the hull from each end. It must be made clear that all hulls of that particular class should be supported for measurement in the same way, and it should be part of the class rules or hull measurement instructions if possible.

Some classes have developed special jigs for hull measurement at events:



Figure D.1.3.2 *The Spanish 470 Jig developed for the 1992 Olympic Games*



Figure D.1.3.3 Spanish 470 Jig with a hull on top (left) and the modular framing and levelling screws detail (right)



Figure D.1.3.4 The 2004 Europe Jig



Figure D.1.3.5 The Europe hull inside the jig levelled and aligned using car jacks



Figure D.1.3.6 *Jig details*



Figure D.1.3.7 *Levelling feet*

The systems shown above are ideal but usually they are expensive, and in the case of the 470 and the similar Finn ones, they are bulky and thus not easy to transport even when dismantled. They require significant time and care to assemble and align, and require a solid concrete floor to rest on. During measurement, they need to be checked frequently for alignment and guarded against accidental movement.

D.1.4 Hull Sections

The shape of the hull is usually checked by measuring the shape of a series of sections through the hull, each a set distance from a reference point (Hull Datum Point). Distances are to be measured along the defined baseline.

Section measurement using templates

Having located and marked up the measurement stations in one of the way described above, the following procedures may be generally used to set up the templates, unless otherwise stated in the class rules:

Position the template with its centreline coincident with the centreline of the boat and with one face of the template coincident with the station marks. Templates located in the "hull coordinate system" should be initially rotated until the gaps at the sheerlines are equal.

Measure clearances all round template, where necessary recording both maximum and minimum clearances.

Measure height of sheerline on each side.

It is essential that the template is accurately located, particularly towards the ends of the hull, since the shape of the hull changes rapidly towards the bow and stern and a small error in position can make a significant difference to the clearance recorded. The template can be held in its correct position using folding wedges at or near the sheerline as shown in figure D.1.4.1 or plasticine pieces (figure D.1.4.2). At the centreline masking tape or plasticine will hold the template in place.

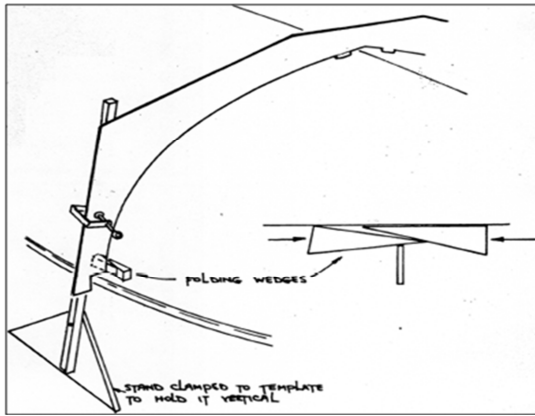

Figure D.1.4.1 *Template support*



Figure D.1.4.2 *Template fixing*

Clearance between the template and the surface of the hull is best measured using a steel ruler held parallel to the face of the template (figure D.1.4.3).

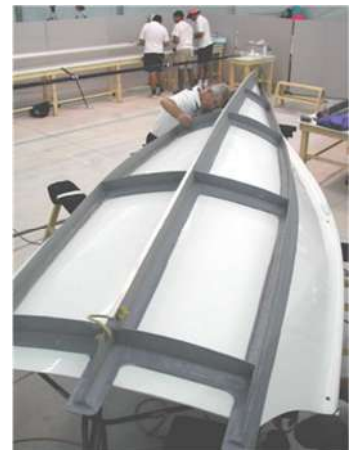

Figure D.1.4.3 *Ruler measurement*

Hull measurement with a model template

Some classes like the 49er have used at times a hollow hull template made from the master plug to check the compliance of the hull. The hull template can be easily fitted to the inverted hull and a visual inspection can be undertaken in a very short time.

The only other tools required are a ruler or a set of feeler gauges for measuring the gap, if found, between the hull and the template. Any variation is then checked against the tolerance as specified within the builders' construction manual.



D.1.5 Fairness of the surface of the hull

Several classes require the measurer to check that the surface of the hull is fair. This is normally done with the hull inverted, by laying a flexible batten on the hull surface. The ends of the batten are held down on the surface and the area of contact examined.

What is being looked for is an unfairness which will be shown by the presence of a 'hard spot' which causes the batten to lie away from the hull, or by a definite concavity in the surface. A concavity can be detected by means of a straight edge.

Care should be taken when examining a hull for fairness that a gap between the batten and the hull caused by the fact that the batten does not take up the same curve of the

hull, is not mistaken for a gap caused by a 'hard spot'. Often it will be found that the batten, when held at its ends on the hull surface, will not lie on the surface. Light pressure applied to the batten over the centre of the gap will normally close the gap completely. If it doesn't, there may be a hard spot and therefore unfairness.

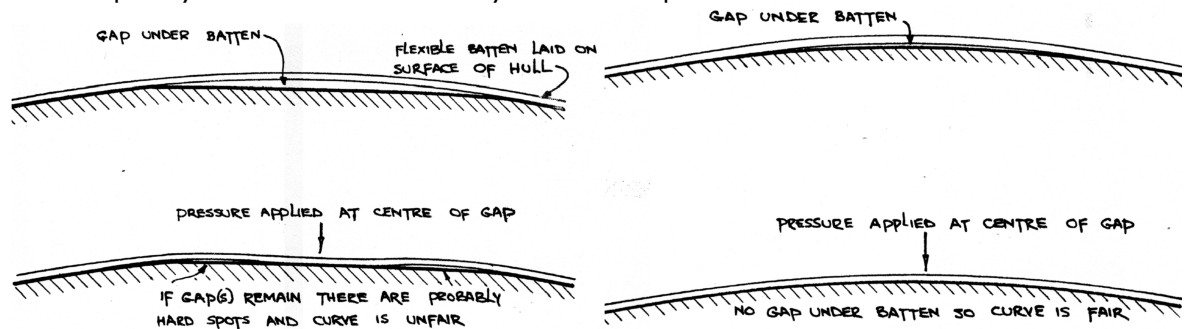

D.2 Hull Weight

The class rules lay down the condition in which the boat is to be weighed and what equipment has to be on board, and what is excluded. Under ERS, there is a clear separation between **hull weight** and **boat weight**.

Hull weighing conditions

In all cases the boat must be dry and there must be no water in the boat or in the buoyancy compartments. Likewise there must be nothing on board that is not required, or permitted to be included in the weight.

Wind can affect the recorded value of weight. Even though the scale may be registering a steady weight there may be a steady up thrust or down thrust due to wind. It is therefore important that the boat be sheltered from the wind while it is being weighed.

The weighing machine has to have adequate capacity and preferably should be operating within about the range of one-half to three-quarters of its capacity.

The weighing machine should preferably be calibrated before use with a calibration weight similar in weight to the expected weight of the boat. Regular calibration is particularly important for electronic scales and load cells. Wear in mechanical weighing machines affects their accuracy and any error needs to be known.

The measurers should be careful to avoid a zero error. The weight of the slings is not normally included in the weight; therefore the reading of the scale with only the slings on



it should be noted and deducted from the reading obtained with the boat on it. This procedure automatically takes account of any zero error in the instrument.

Weighing at Major Events

The quality of weighing results depends on:

- the equipment,
- the conditions,
- the qualifications of operators.

Hull weighing should be performed using Class III scales, with a display step of 1/3000 or 1/6000 of their measuring span (i.e. 50 grams for a 150 Kg scale). Usability in legal metrology and legal trade provides, in general, a guarantee for the obtained reading under ideal conditions. If the scales are not verifiable for legal metrology, credibility is provided by a valid calibration certificate. Span adjustment, which is sometimes also referred to as calibration, is not sufficient. Weighing within the first 50 display steps is also prohibited by legislation. If it is still necessary to weigh small objects, it is recommended to place a larger object on the scales, tare the weight of this object (zero weight appears on the display) and then determine the weight of the small object (unfortunately it may be inaccurate due to the large step value).

Platform scales are easier to use but need a protective pad or a cradle to set the boat on top.

Hanging scales need slings and more people to lift the hulls: they may also take more time to settle for taking the readings.

The weighing station should meet the following requirements:

- (a) - Change in the temperature of the environment should be minimized
- (b) - Direct sunlight to the scales must be avoided
- (c) - There should be no vibration or strong draught
- (d) - Scales must be on a stable base and levelled (floor scales)

A check in accordance with the scales manual is recommendable before official weighing. The verification or calibration marking of the scales must be clearly legible and the verification or calibration date (period) valid. If no documents are available, then the following tests help to establish the suitability of the scales:

Place a load in the centre of the platform (20% of max. load) and tare the scales reading. When you now weigh the load on the corners of the scales and the difference with the tarred quantity does not exceed one step, things look good.

Sensitivity test: Put a load of about 50 display steps on the scale. When a weight equalling the value of one step is added, the reading must change by one step.

Deviation of readings: Repeatedly place the same load on the scales. The reading should not change. A few occurrences of a 1 step change in the same direction are acceptable. The scale reading should be the same on unloading as for loading, i.e. no hysteresis.

For multi-pad scales, such as used for catamarans the reading should be the same as each pad is loaded, and subsequently the reading should be the sum of the pad loadings.

It is certainly necessary to carry out a span adjustment during which the scales are “told” the value of gravity acceleration at the place where the weighing takes place. Electronic scales measure the force applied to them and the mass that we are interested in is calculated with the formula $M = F/g$. In this formula g is the local gravity acceleration value, which takes into account the latitude, the altitude from the sea level, geological conditions, etc. In practice a good indicator of the conditions is the stabilizing of the scales reading. If the reading of proper class III scales has problems stabilizing, there are problems with the conditions, the weighing results are unreliable (due to the conditions) and reading should not be used. A typical example is the weighing of keelboats outside in the wind. If a stable reading cannot be obtained, you should find suitable conditions or a place with less wind. Nobody has the right to force a measurer to breach professional ethics.

A measurer cannot be at all measurement stations at the same time. Although scales develop towards the simplification of procedures, a certain problem is often presented by the training of assisting persons. It must be taken into account that this takes quite a lot of time. Once a stable reading has been reached, a new character appears. The rules usually provide the weight of the boat together with certain equipment in dry condition. A boat meets these conditions when brand new. A dry boat that has been sailed is heavier than a new dry boat etc. Damp control lines are surprisingly heavy and some competitors dampen them on purpose. There is no point in weighing a boat that has been out in the rain prior to weighing! A “Finn” that has sailed today is up to 1.5 kg overweight even after two days.

Almost each boat class has an official procedure for weight correction. In practice this situation can be avoided only by the class measurement consistency and educating of the yachtsmen. The majority of yachtsmen violate the rules because they are not familiar with the rules. Indeed we should start from teaching. A measurer is also a teacher: Everybody must be treated equally, each case is a new one and old sins do not count!

In case of wet boats at an event:

- If it is hot and sunny, the crew must dry the boat and come again.
- If the weather is wet, it might be possible to compensate for the extra weight, based on each boat’s actual condition.

In case of bad weather at events, it is better NOT to check equipment weight at all.

SECTION E. HULL APPENDAGES

Hull appendages are items of equipment found wholly or partly below the sheerline or its extension when fixed or when fully exposed if retractable; they are attached to the hull or to another hull appendage and they are used to affect any or all of the following: stability, leeway, steerage, directional stability, motion damping, trim and displaced volume. ERS 2025-2028 don't offer a standard set of definitions other than the various type names, so uniformity in measurement methods is impossible. Therefore, classes follow their own systems but in general, class rules may control

- Profile shape (width and length, edge shapes)
- Section shape (thickness in various points)
- Position relative to hull
- Weight
- Materials

In most cases, inspection of hull appendages at events is carried out using the same methods as for certification measurement, especially when their shape is controlled by templates. The obvious difference is that there is no need to record actual values; therefore special go/no go templates may be constructed that only mark the limits using scribe lines or coloured areas. For example, in the case of a centreboard pivot position, one can outline the permitted positions and paint either the inside or outside area in a distinctive colour: the inspector only needs to see through the pivot hole and check that the centre is on the properly coloured area when the board is placed on the template.

E.1 Profile

The profile of a hull appendage, that is the shape when viewed from the side, may be controlled by one of three methods:

- Measurements stated in the class rules,
- Plan or measurement diagram giving dimensions,
- Template.

The effect of each method is the same, to control, within tolerances laid down in the class rules, the shape of the appendage.

Where it is a requirement that the board or rudder is laid on a plan it is essential that any instructions in the class rules on how this is done are followed exactly. For instance, the leading edge of the board may have to be over the leading edge indicated on the plan.

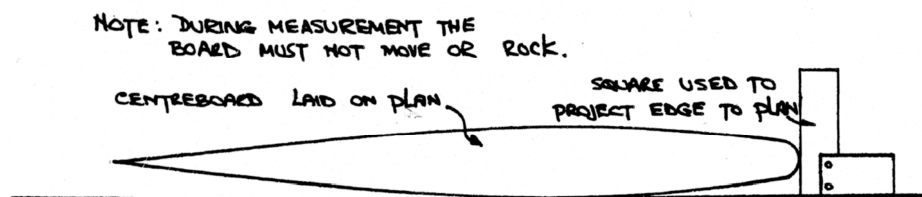

Figure E.1.1

The thickness of the board makes it difficult to check its conformity with the plan. The measurement has to be carried out on a flat surface, using a small square or similar tool to project the edge of the board down to the plan.

When a template is used the position of the template in relation to the centreboard can be varied in order to achieve the "best fit". If the measurement is carried out with a solid template the remarks above concerning laying the board on a flat surface apply. If the template is a hollow one which fits round the board the problems are not the same and, depending on the class, the measurement may be carried out with the board in the boat and fully lowered. In this case, if the board has to be in the fully lowered position there must be stops to prevent it being lowered any further.



Figure E.1.2



Figure E.1.3

Appendages should be carefully positioned on templates, observing any datum or other reference points. Depending on the specific class rules and the shape of each appendage, edge and corner shapes may be checked individually as in the 470 centreboard and rudder shown below, or the whole blade checked at once like the Finn rudder shown above.



Figure E.1.4

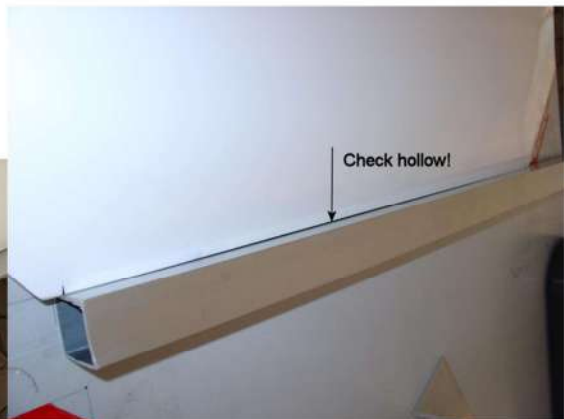

Figure E.1.5



Figure E.1.6 *Radius check.*



Figure E.1.7 *Profile check with mylar template.*

E.2 Section

Section shape is usually controlled by measuring the thickness of an appendage, although this may be also achieved indirectly i.e. by limiting the width of a board slot in the hull.

Where a minimum and/or maximum thickness is specified in the class rules this can be measured using inside/outside callipers. However, a purpose made go/no go gauge is the tool of choice if many boards for the same class have to be measured. This gauge can be used in conjunction with either a calibrated wedge or a stepped gauge to obtain the actual thickness. A custom made system using an electronic micrometre can give the

actual thickness in virtually every point of the appendage, but the board must be properly placed inside it.

Some classes require their appendages to be of even thickness. In order to check that this is the case, it is necessary to take several measurements of the thickness. It follows that if the centreboard is symmetrical and of even thickness the two sides must be flat, and therefore two straight-edges placed one on each side must be parallel and touch the surface of the board. However boards warp sometimes and therefore may not be flat. A variation of thickness of 1 mm is normally permitted, but in some classes the tolerance can be ½mm.



Figure E.2.1

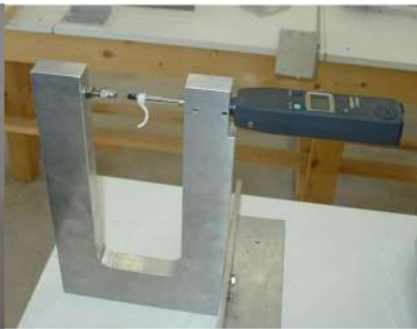

Figure E.2.2



Figure E.2.3



Figure E.2.4

For foils of even thickness, the leading and trailing edges need to be checked to ensure that the bevelling does not exceed the permitted limits.

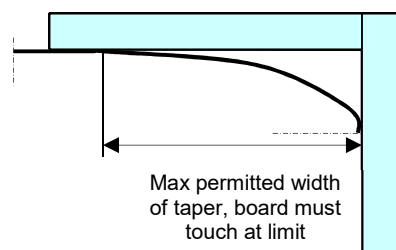

Figure E.2.5



Figure E.2.6 *Thickness control.*

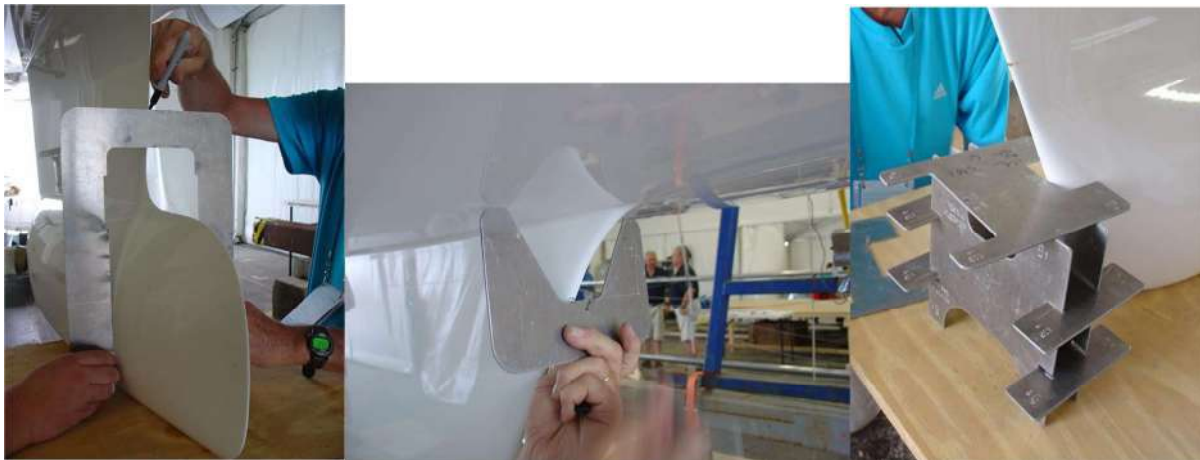

Figure E.2.7 *Section marking.*

For most dinghy and multihull classes only the profile of the immersed part of the rudder and board, as well as the maximum section thickness and edge radii or tapering is controlled. However, for keelboat classes the keel shapes are a critical factor in boat speed and are therefore carefully controlled in both shape and alignment.

Care should be taken to ensure that the gap measurement is made at the appropriate edge of the template, and ideally ball bearings of the appropriate minimum and maximum sizes should be used to test the gap.

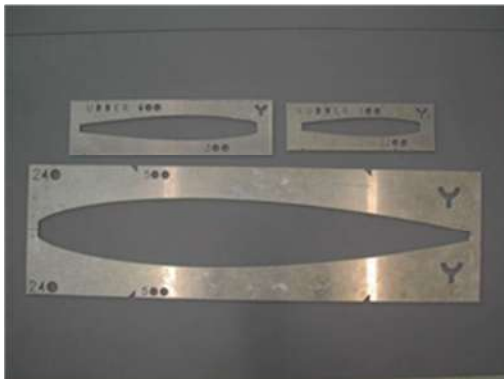

Figure E.2.8



Figure E.2.9



Figure E.2.10

E.3 Position

For fixed appendages, the position may be controlled by a direct measurement from appropriate datum point(s) on the hull, to specific points on the appendage itself (i.e. the lowest point, or one of the corners at the bottom etc.).

For movable appendages, it may be done indirectly through a reference datum (i.e. the centreboard pivot position on hull and board, the ends of a daggerboard case on the hull etc.).

However, it is also possible to control the position of a movable appendage directly when it is positioned on the hull. The maximum extension of a centreboard below the hull is taken, as the words indicate, when the centreboard is in the position of maximum depth. This is normally, but not always, when it is in the 'fully down' position.

The measurement is most conveniently made with the boat on its side and, initially, with the centreboard in its full-down position, as follows:

- Identify the lowest point on the tip of the board,
- Measure the distance from that point to the nearest point on the keel,
- Repeat the measurement from another point at the tip of the board if there is any doubt, about which point gives the greatest depth,
- Repeat steps (a), (b) and (c) above with the centreboard slightly different positions,

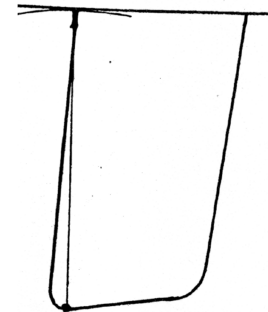

The greatest measurement obtainable is the maximum extension of the centreboard.

The depth of the rudder blade below the hull is normally taken in the same manner. It is -unless otherwise indicated in the class rules- the vertical distance below the lowest point of the transom, which means that the hull must be also properly levelled before.

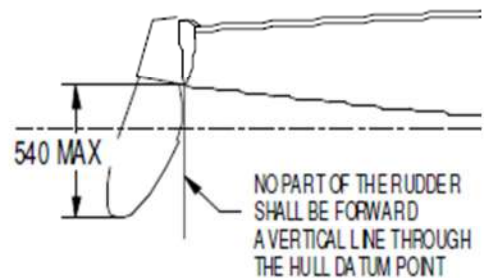

In the example to the right, class rules specify the length of the rudder when positioned on the hull as the minimum distance from the hull underside, the position of the leading edge relative to the Hull datum point, and the angle of the blade by checking the distance from the lowermost point to the HDP.

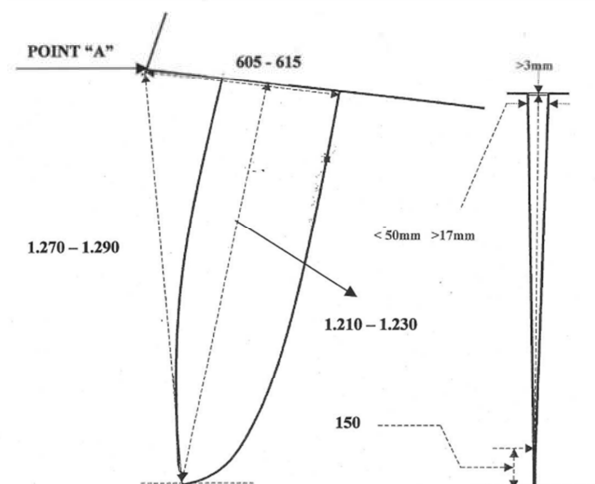

Similarly, keel fore and aft position may be controlled from the HDP, and depth from the keel line at certain stations. In some cases, this may be conveniently done with purpose made gauges as shown below.

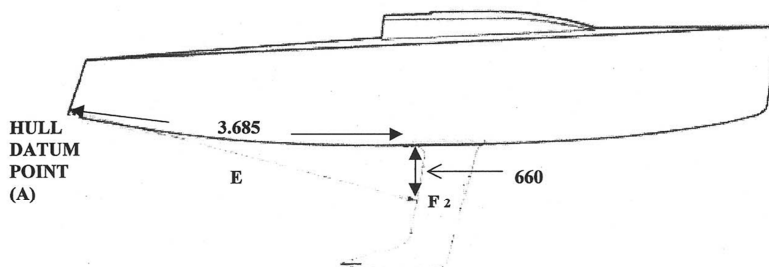

Figure E.3.1



Figure E.3.2

It may be also necessary to check the position of the pivot of a centreboard or lifting rudder. The pivot may be positioned relative to reference lines such as the leading and bottom edges of the foil. In the example below, the rudder jig has the limits of the pivot position marked with a red outline, leaving the white coloured inside to show the min/max area.



Figure E.3.3

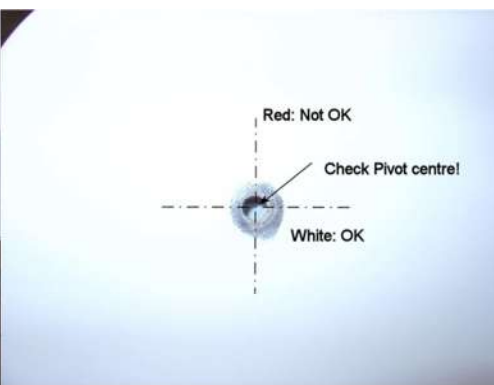

Figure E.3.4

E.4 Other controls

Appendage weight may be also specified in class rules: boards and rudders may be checked at any time using scales, but keels are normally controlled at the time of manufacture, before they are fixed on the hull. This makes it impossible to check them at an event. Materials are also limited in some cases so measurers should be able to identify and recognize them with a visual or other non-destructive control. Destructive sampling should be undertaken only after consultation and permission of the appropriate authority.

E.5 3D-Scans

Recently, WS has used 3D-scanning technology to inspect appendages of the foiling Olympic Classes. The particular equipment used was the AS1 Kit V2P hand held scanner with a 7-axis Hexagon Absolute Arm V2P 8230, while the software used was the PolyWorks Inspector. The hardware can be transported as oversize luggage on commercial flights and the WS team has travelled to many countries in Europe and Asia to perform production tolerance audits of hydrofoil manufacturers and conduct event inspections for the IQFoil, IKA Formula Kite and the Nacra 17.



Figure E.5.1



Figure E.5.2

Data Collection

This technology has been particularly helpful in speeding up the data collection process. Inspection times have been reduced to the point where the team can scan the full surface of an iQFOiL and IKA Formula Kite Frontwing in 3 minutes or the full set of hydrofoils (Frontwing, Rearwing and Foil Mast) in 10 minutes. The 3D scanner is able to acquire data of larger equipment, World Sailing have scanned ILCA hulls for example, but the equipment can also be used with bigger surfaces as it is possible to merge different scans as long as the scans overlap.

Measurement Tools

The 3D scanner collects a cloud of data points that can be either worked with directly or converted into a surface mesh by the operator. This data can then be analysed against a design CAD file or other data point clouds. Below are some examples of the measurements that can be analysed:

Calipers

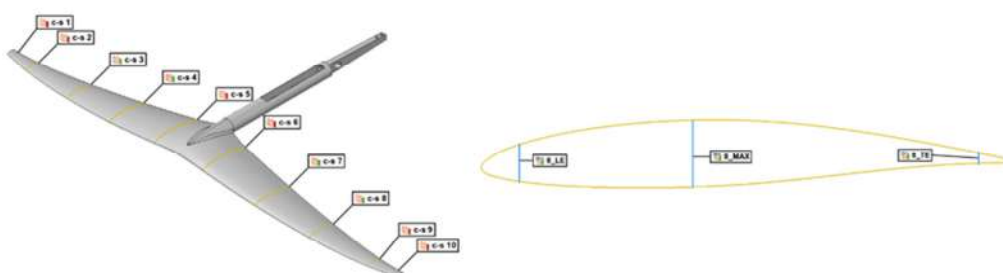

Figure E.5.3

The design CAD file of the equipment can be sliced with sections, on these sections, as many Callipers as are required by the analysis can be added. The Callipers measure the thickness at specific points of the cross sections, these measurement tools can be used to check if equipment has changed from its intended design and can be used to identify if equipment has been manipulated by sanding or coating the surface. Callipers can be also used to measure the equipment without the creation of cross sections, in the image below the span of the foil is measured with Callipers.

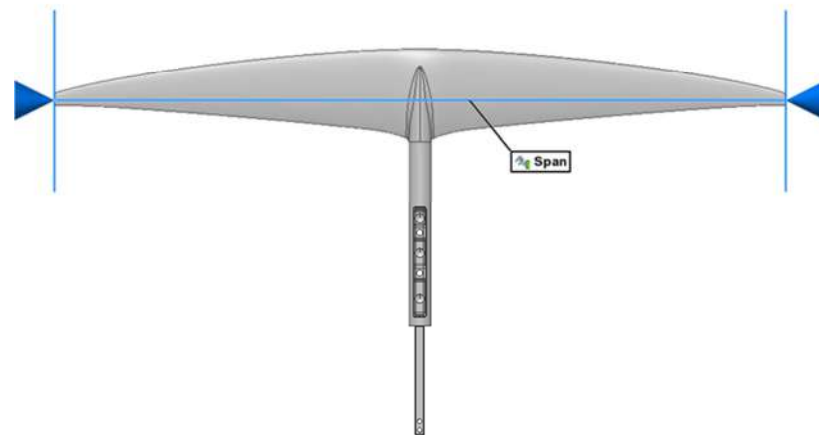

Figure E.5.4

Surface Comparison Points

The Surface Distance Points measure the spatial distance between the Upper and Lower surfaces of the design CAD file (grey) and the scanned equipment (yellow). Surface Distance Points provide information regarding deflection and changes of the equipment in the space, they can be used to conduct studies linked to the effect of equipment usage over time.

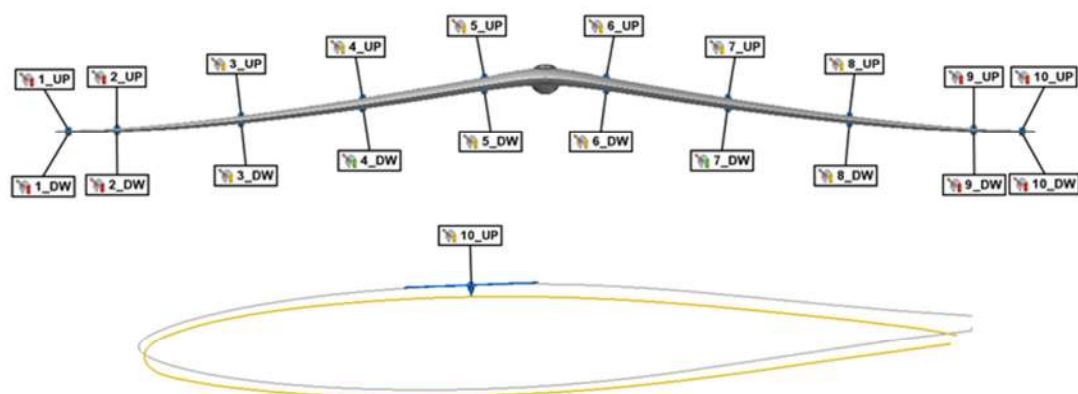

Figure E.5.5

Colour Maps

The Colour Map gives a measure of the spatial difference between the Upper and Lower surfaces of the design CAD file and the scanned equipment, it provides a general overview of the equipment and can be used to detect trends or areas of interest where the inspector can focus their attention during the inspection.

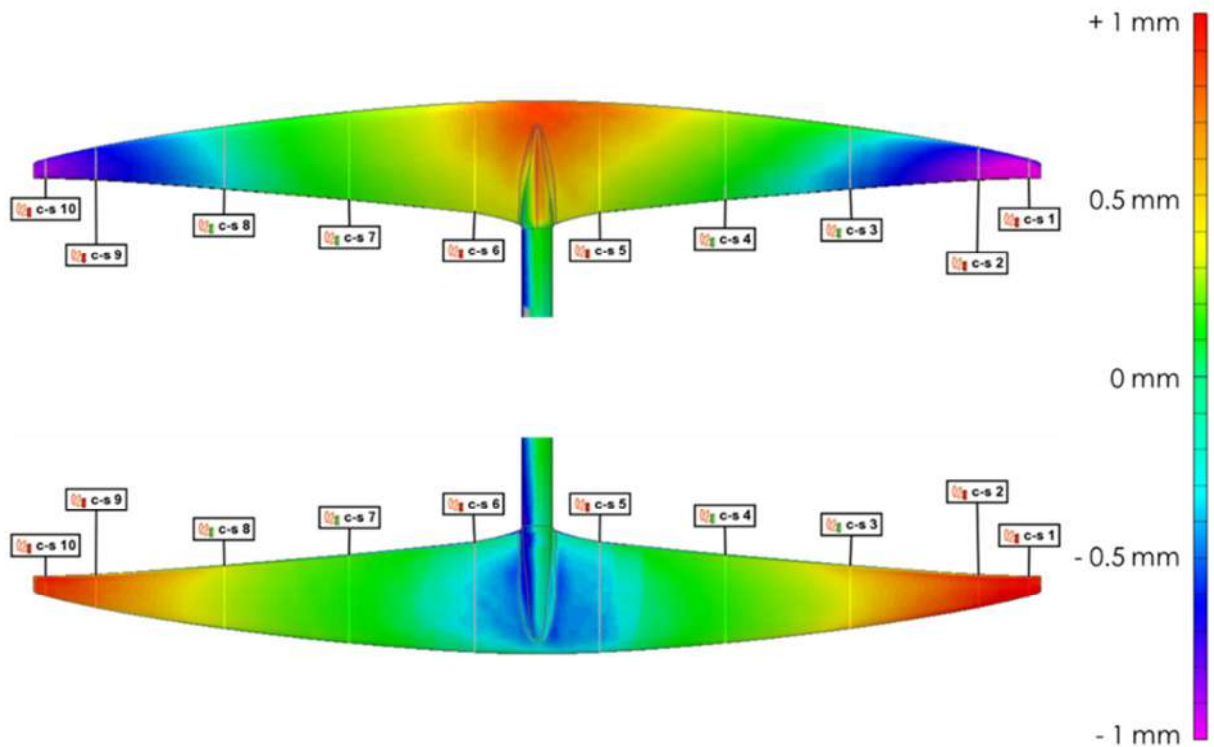

Figure E.5.6

SECTION F. RIGS

ERS 2025-2028 Section F provides a set of standard definitions for rigs (spars, rigging, spreaders, measurement points, dimensions and all associated fittings) facilitating uniformity in measurement methods and tools across classes. Many classes use these standard definitions and also have their class rules in the SCR format. Each of the following sub-sections deals with the main aspects of rig measurement and inspection in detail.

F.1. Introduction

The parameters that control the performance, strength and cost of a mast spar, and so are likely subjects of class rules are:

Material, i.e. wood, the aluminium alloy and temper, carbon fibre, its modulus and resins

The spar extrusion weight per unit length, or wall thickness

The spar fore and aft and transverse dimensions

The spar extrusion transverse and fore and aft areal moment of inertia

The sail track, integral or separate

The extent and dimensions of the mast taper

Mast curvature and deflection

The rigging points for stays and shrouds, spreader dimensions

Sail hoist heights

Many of these properties are interrelated and so classes choose different combinations.

Rig inspection usually starts from the definition of measurement points: some of these are associated with limit marks which are meant to dictate proper setting of sails or other spars. Lengths –or heights when referring to masts- are then measured with reference to those points, but class rules may specify additional limitations on items such as spar section, deflection, curvature and weight, rigging specifications etc. ERS H.4 specifies conditions for measurement, which in the latest ERS cannot be modified by Class rules. Event inspection for dinghy rigs is better performed on purposely built tables, using marks for minimum and maximum limits instead of tape measures. This is impossible for larger boats which have to be inspected with the same methods as for certification measurement, using tape measures and properly trained people.

F.2. Spar measurement points and limit marks

ERS specify a number of measurement points on spars: some are related to the geometry of the rig (e.g. rigging points) and others are used for setting sails or other spars. The latter are indicated by using limit marks (measurement or “black” bands). These are required to be marked distinctly (in a colour contrasting sharply with that of the spar) or even additionally engraved/punched on spars so as to be clearly visible while racing. Some classes require additional bands to indicate the positions of the forestay or spinnaker halyard.

The first measurement point on masts is called **Mast Datum Point** in ERS, and it is the datum for measurement. Other measurement points –except from the points defined on the extremities of the mast- and distances are taken with reference to the MDP. The datum point is defined in Class rules and is usually connected to one of the following:

- heel of the mast, or
- sheer, or
- deck in way of mast.

Measurement from the heel is usually referred to the heel point (ERS) but in non-ERS classes it may refer to the bearing point of the mast. A mast which has a tenon may have its bearing point either at the bottom of the tenon or on the shoulder. It may be then necessary to check the mast step in the boat. Mast datum points that refer to the heel point make measurement and inspection easier, because it is independent of the hull and the mast step fitting. However, the heel is subject to wear, so measurements taken on a new mast may change progressively after extensive use.

ERS specify two limit marks on masts: the lower and the upper, which are associated with the lower and upper points respectively (Figure F.2.1). The upper mark is used for setting the mainsail, while the lower mark is used for setting the boom.



Figure F.2.1 Mast Upper and lower marks and points

The band on the boom is located with reference to the **aft face of the mast** but excluding the effects of local curvature or cut away track.

F.3. Weight

The way in which masts are weighed varies considerably so that it is necessary to follow precisely the requirements laid down in the class rules.

Mast center of gravity measurement

A number of classes specify the lowest acceptable position of the centre of gravity of the mast. A tip weight as specified in the ERS is required by other classes. In order to carry out the measurement of the location of the centre of gravity, the mast is prepared together with the appropriate fittings and the spar is then supported horizontally at its point of balance. The distance to the heel is then measured.

Determining the CG of a mast only requires a knife edge or inverted angle section on which to balance the mast, so sailors can easily check this themselves. For regatta

inspection the knife edge is set at the minimum distance from the datum point. Then when let go the tip of legal masts must go down. This is a quick and definitive "Go-No go" test requiring no equipment and the results of which are not open to discussion. Once the CG is located it is a simple matter balancing the mast on a scale for weighing.

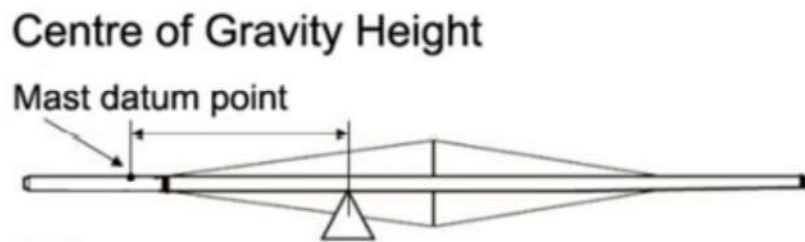

Figure F.3.1 Determination of the mast CG by balancing on a knife edge. For regatta inspection the knife edge is set at the minimum permitted distance from the datum point and the mast tip must go down when released.

Mast tip weight measurement

To overcome the problems frequently associated with the measurement of the position of the centre of gravity, especially for bigger masts, the "tip weight" test was introduced. In this test the rigged mast is supported at the lower point and the weight of the spar at its top point taken. Halyards are fully hoisted and their tails allowed to rest on the ground. Shrouds, forestay and backstay are tied to the mast spar at the lower point with the lower ends allowed to rest on the ground.

In conducting the weight measurement the measurer has to be satisfied that any shackles etc. are of normal weight and are not being used as a means of increasing the mast or tip weight. The same remarks apply to the halyards.

During regatta inspection, tip weight and total mast weight may be measured simultaneously using scales at the upper point and the lower point. The halyard should be hoisted with the shackles (of less than maximum weight) at maximum height, and their (dry) tails supported on the lower point scale as they are part of the mast weight, but they shall not affect the tip weight. Spinnaker pole and any other movable fittings should be at maximum height ("worse" position for the measurement).

Both tip weight and CG height rules have to specify the conditions and procedure for measurement, and the permitted positions for installing corrector weights.

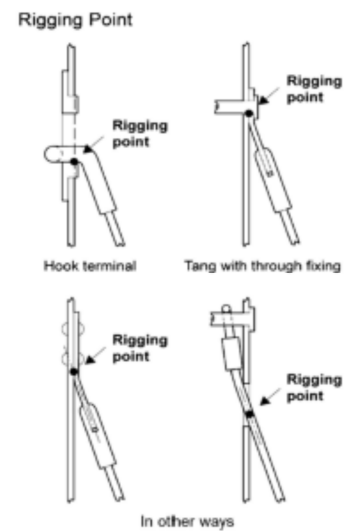

Figure F.3.2 Mast weight / centre of gravity (left) and tip weight (right) measurement. The centre of gravity may be checked using a knife-edge to balance the mast.

F.4. Rigging points

Shrouds and stays are usually attached to tangs on the outside of the mast, fixed internally or hooked into slots in the spar. The ERS specify some distinct situations in order to define the rigging points which are used for measuring the distances (heights) from the mast datum points.

Spinnaker hoist height is measured between the datum point and the lower edge of the spinnaker halyard when held at 90° to the spar, so in effect it is measured to the sheave or block bearing point.



F.5. Booms & Poles

Boom measurement usually includes the Outer point distance from mast spar. Under the ERS, boom measurement has to be done with the boom connected to the mast. In addition, there may be section and weight measurements as with masts.

The only measurement usually required to be taken on a spinnaker pole is its length. This is the overall length (ERS) and is measured to the outer ends of the fittings, and ignores the point which the spinnaker guy will bear. If the mast fitting for the spinnaker pole is to be measured, the height measurement is taken to the centre of the ring and the distance from the face of the mast is taken as the greatest measurement and is irrespective of the position of the bearing surface.

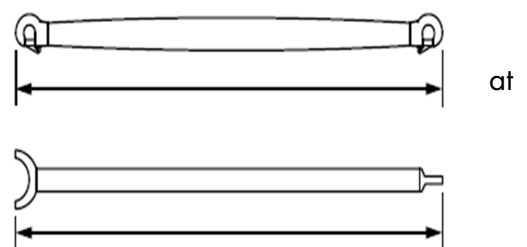

F.6. Rig Inspection Tables

A rig inspection table should have a flat, clean surface, preferably of melamine; its length should be enough to accommodate fully a mast inside, and wide enough for any required accessories like a scale to fit on top. A second table for the boom has to be fitted perpendicularly to the mast table (both must have the same height!) and this has to be wide enough to accommodate both the boom and spinnaker pole. If the boom is to be measured separately from the mast, then one table is enough for everything. Such a setup may be prepared as follows:

Mast table

- A reference line has to be drawn lengthwise: that will be the reference for the positioning of the sail track edge of the spar and the height/length measurements.
- The datum point marked on the reference line (Easier if it is the heel point)
- Measurement and rigging points marked on the reference line
- Spar stoppers/guides fixed on the reference line above the below the spreader position (or at two points above the boom if there is no spreader)
- Datum point stopper fixed (a strong angle)
- Mark lines drawn at the measurement points and covered for protection with clear tape.

Boom table

- Reference line drawn perpendicular to the mast reference line at the lower point position.
- Outer point marked on the reference and a line drawn and covered.
- Second line drawn for the pole. Zero point and maximum length point marked.
- Stoppers (e.g. strong angles) fixed at both points.



Mast and boom table layout: A strong fitting fixed securely on the table is required for setting the mast heel especially if this is the datum point. Whatever system is used, its mast heel bearing surface should be vertical and perpendicular to the line of measurement.



If the mast has spreaders, a cut-out or separation of the table is necessary for the mast to sit properly. The same should happen if the masts have fittings, compass brackets etc. that will prohibit their proper alignment on the table. Rigging and other measurement point mark lines should be color-coded and protected. A scale with proper cradle should be positioned near the centre of gravity (if checking the mast weight) or at the top if doing tip weight checks. Centre of gravity checks may be done using knife-edges as shown below. For unstayed masts, hanging scales are most convenient provided they have a spread hook to allow quick balancing of the mast.

Special tools are needed for mast spar alignment such as the cylindrical fittings shown to the right, or even simple aluminium square sections.

Ideally, go-no go gauges should be used for checking spar section dimensions.



Use of a rig inspection table:

Check the Class rules carefully!

STEP 1: FIND AND MARK the Mast Datum Point

STEP 2: MARK the other Mast measurement Points, in most cases only the upper and lower points.

STEP 3: MARK the Rigging Points if relevant.

STEP 4: MARK any areas for the mast spar cross section check and the points for deflection tests if any.

STEP 5: Commence inspection of dimensions using the marks on the rig table.



The mast heel must be pushed and kept firmly against the heel stopper. In this example the heel point is also the datum point. The spar has to be also kept tightly against the two stoppers on the mast reference line.

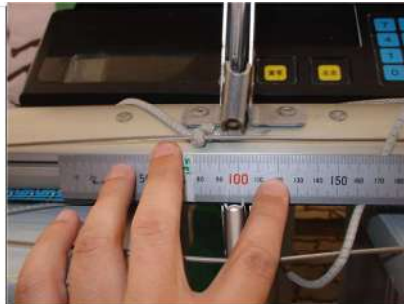
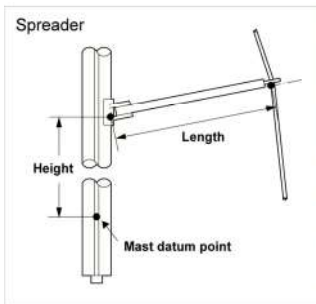

If there is a spreader cut-out, a reference point should be marked on the table before the cut to serve as a spreader height datum. Rigging height marks should be extended to be visible both from the fore and aft edges of the spar.

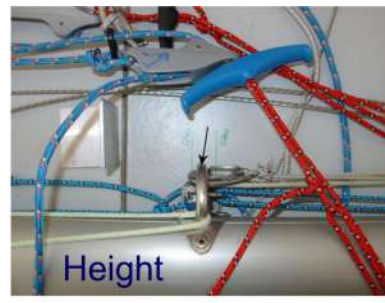

Spinnaker hoist height (left) with the halyard held at 90° to the spar.
Spinnaker pole fitting height (right) from the center of the fitting.



Marks on the table should be projected on the spars with a square, never eye-balled.



Knife edge used to check the centre of gravity position. It is positioned at the centre of gravity limit (usually only a minimum distance from the heel) and the mast tip should touch down when the mast is placed on the edge. Go/no go gages or calipers may be used to check the cross sections.

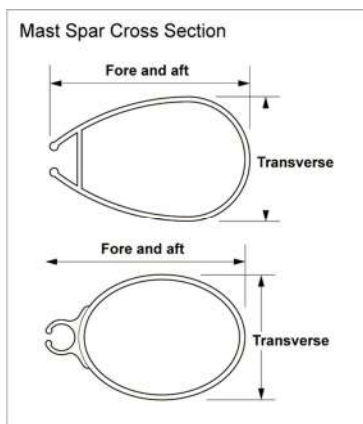

With the boom and mast joined together, the boom position relative to the lower point may be checked: the top surface of the boom (bottom in the picture above) must be at the same height as the lower point or higher. The visible gap in the picture indicates that the boom is improperly positioned.



The position of event limitation marks (usually stickers) is also important, because the stickers have to be visible on the water, but also protected from wear and tear. They have to be positioned at the same place on all boats so that the inspectors know where to expect to find them.

SECTION G. SAILS

G.1 Sail inspection

Event inspection of sails should be carried out under cover in good conditions of light, without wind or draughts and ideally, should be carried out on tables. These should be about 90 to 100cm high with a single flat working surface, although separate tables with their legs taped together will often suffice (Figures G.1.1 and G.1.2). Measuring on tables eliminates the need to bend down and to kneel and thus minimizes the fatigue associated with sail measurement. If tables are not available then a gymnasium or dance floor is a good measuring surface.



Figure G.1.1 *Sail measurement table*



Figure G.1.2 *Sail measurement table*

Sail inspection should be undertaken using templates and measuring battens for small and medium size sails. Large sails should be measured with steel tapes, with the same techniques as used for normal certification measurement. In most cases, large sails have to be inspected on the floor because of sheer size that prohibits the use of purpose built tables.

The conditions for sail inspection are the same as those for sail certification control. ERS H.5.1 gives the conditions for sail measurement, specifying that sails shall:

- be dry
- not be attached to spars or rigging
- unless the **class rules** prescribe otherwise, have all battens removed
- have pockets of any type flattened out
- have just sufficient tension applied to remove wrinkles across the line of the measurement being taken, and
- have only one measurement taken at a time

G.2 Sail inspection Fundamentals

The ERS method follows a logical step by step approach to sail measurement and this applies in the same way for sail inspection. There is no need to specify a single datum point as in spars and hulls, but 3 or 4 corner measurement points, for trilateral or quadrilateral sails respectively. These points are then used for sail edge length measurement, and to define other measurement points on the sail edges themselves. In

addition, there are other measurements independent of those points, for items such as batten pockets or reinforcements, and these are taken directly on each item.

G.2.1 Corner measurement points (ERS G.4)

ERS G.4.1, G.4.2, G.4.3, G.4.4 & G.4.5 refer to sail edges “extended as necessary”. Such cases where it is necessary to extend an edge are:

- When there is a cut-out at the sail corner itself, the associated boltrope, or the tabling. See cases 2, 4, 7, 10 and 11 on Figures G.2.1.1 and G.2.1.2
- When the sail edge curvature changes markedly at a point close to a sail corner, a round-off. See cases 1, 3, 6, 8 and 9 on Figures G.2.1.1 and G.2.1.2

The tack point is the intersection of the foot and the luff, each extended as necessary.

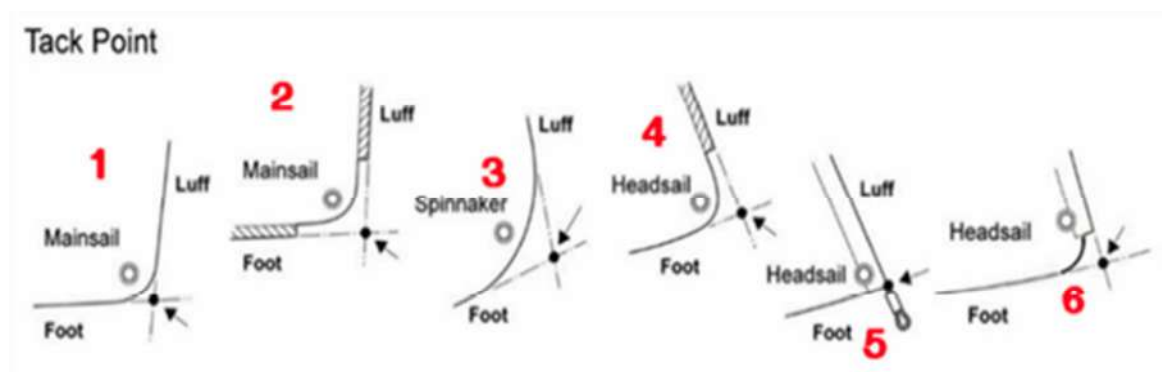

Figure G.2.1.1 Tack point, ERS definition.

The clew point is the intersection of the foot and the leech, each extended as necessary.

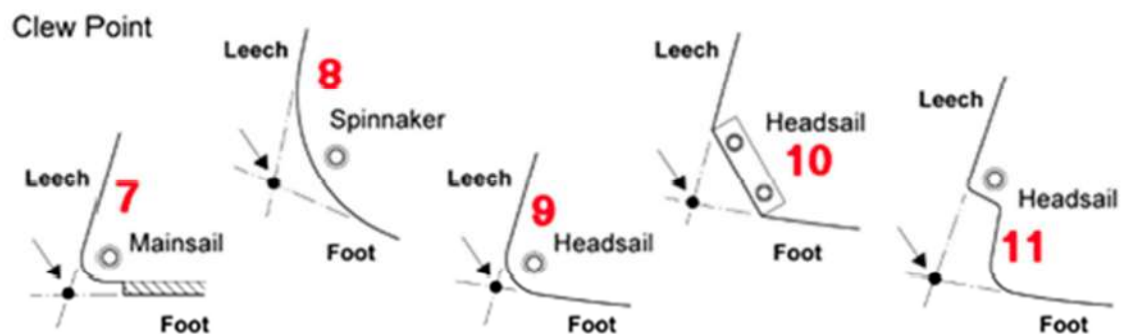

Figure G.2.1.2 Clew point, ERS definition.

The 2025 ERS H.5.4 describes the standard method for extending sail edges as follows:

When there is a cut-out or rounded corner in the sail edges at the clew, tack, peak, throat, spinnaker head or an aft head point, the extension of the sail edge shall be found by extending the sail edges as necessary to bridge the cut-out or rounded corner.

- a) A uniform thickness batten may be used for that purpose, placed along each sail edge and bent in a way to match the curve of the sail edge up to the start of the cut-out or the rounded corner.

b) When the start of the cut-out is not clearly defined and a repeatable corner point cannot be found, ERS H.1.2 shall apply. The certification control may be suspended until the sail cut-out is made clear to the satisfaction of the certification measurer.

c) Batten specifications may be prescribed in class rules. Classes are free to choose if they wish to modify H.5.4 to better suit their needs and their particular sail geometries (H.5.4(f)).

Marking the extension lines on paper taped to the underside of the sail helps to retain the point during measurement (Figure G.2.1.7).



Figure G.2.1.7 Clew point: sail edge extensions marked on paper.

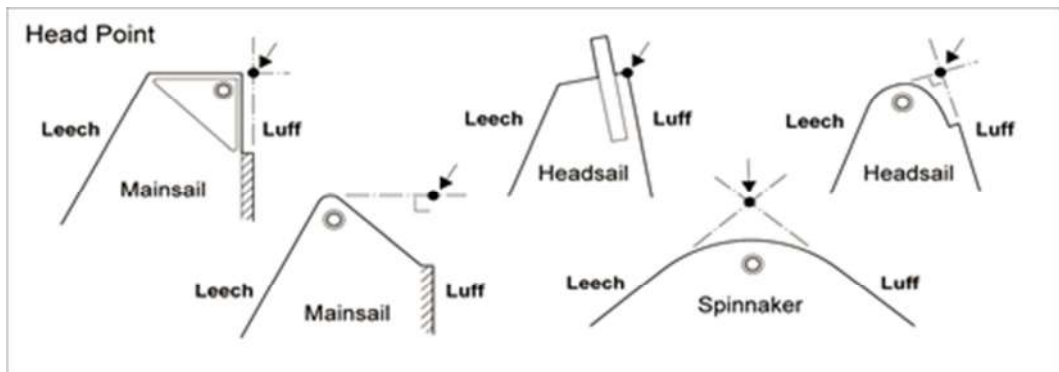

The head point on a mainsail is the intersection of the luff, extended as necessary, and the line through the highest point of the sail at 90° to the luff. In this case, any attachments are to be included (Figure G.2.1.9)

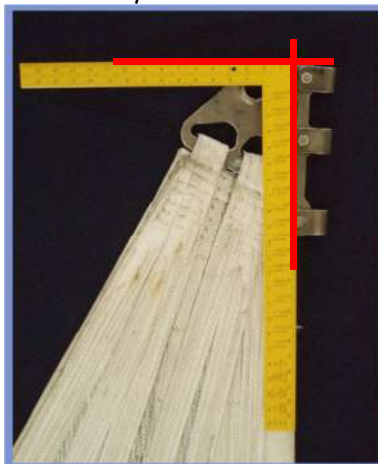

Figure G.2.1.9 Mainsail head point.

On headsails, the head point is the intersection of the luff, extended as necessary, and the line through the highest point of the sail at 90° to the luff but in this case excluding attachments (Figure G.2.1.10)

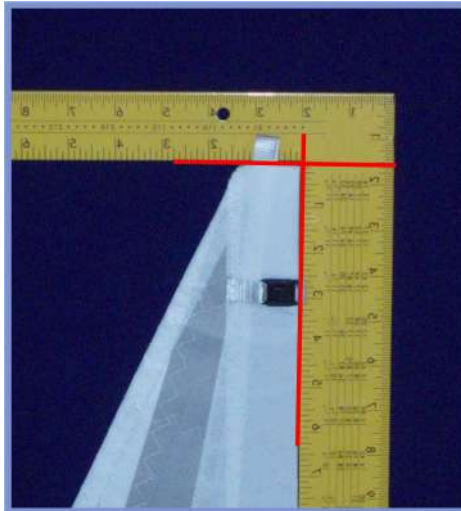

Figure G.2.1.10 *Headsail head point.*

On spinnakers, the head point is the intersection of the luff and leech, each extended as necessary, in the same way as for the clew and tack points.

G.2.2 Sail edge measurement points (ERS G.5)

The half leech point is found by folding the head point to the clew point (Figure G.2.2.1-1) and equally tensioning the two halves of the leech so formed (Figure G.2.2.1-2). The half leech point is the intersection of the fold and the leech (Figure G.2.2.1-3).

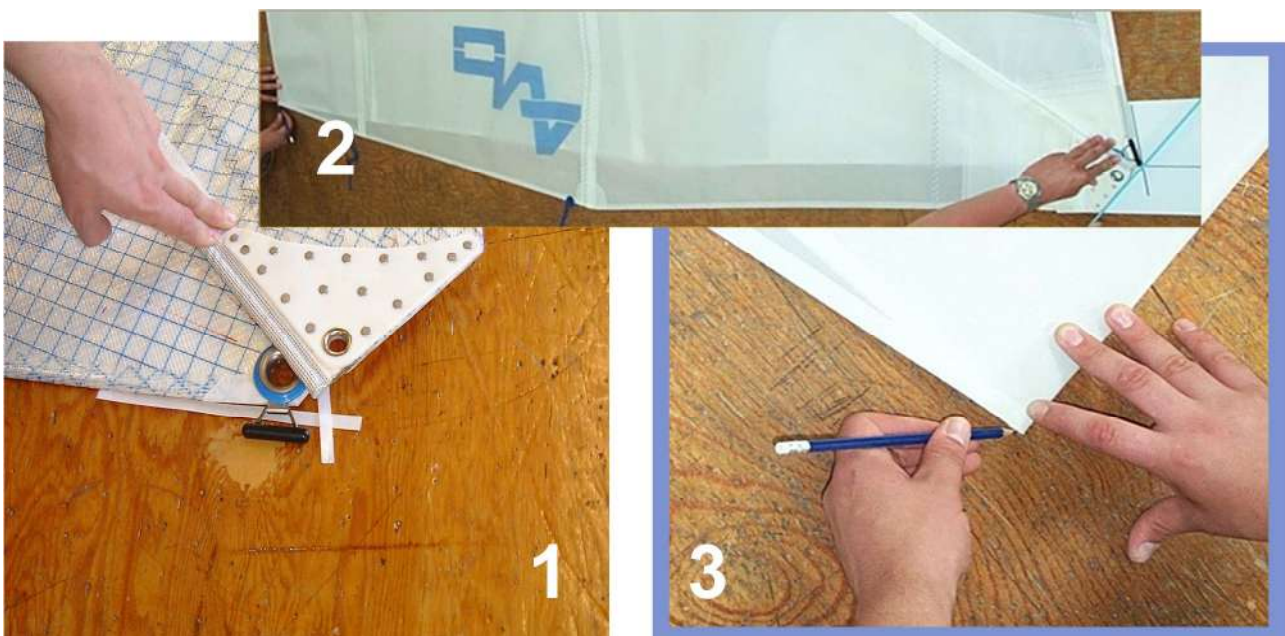

Figure G.2.2.1 *Half leech point.*

The quarter (Figure G.2.2.2) and three-quarter points are found similarly by folding the clew point and the head point respectively to the half leech point. The points are the respective intersections of the folds and the leech.



Figure G.2.2.2 *Quarter leech point.*

For upper point marking, the head of the sail should be flattened and tensioned to remove wrinkles, and then the specified distance measured with a tape from the head point to the leech and marked on the leech. A number of Classes are controlling their mainsail widths at one or more “upper points” and ignore the ERS half and quarter points.

The same technique is used to find and mark measurement points on the luff, using the tack point instead of the clew, and also on the foot, where the mid foot point is found by folding the sail with the clew point on top of the tack point or in the case of spinnakers, one clew point to the other clew point (Figure G.2.2.3).

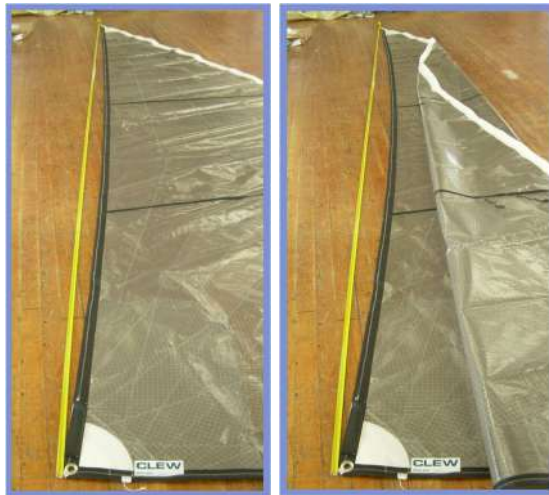

Figure G.2.2.3 *Spinnaker mid foot point.*

G.2.3 Primary sail dimensions (ERS G.7)

Having defined the various corner and edge measurement points, the next step is to measure primary dimensions such as lengths and widths. Sails are to be flattened as prescribed by ERS H.5.1 (Figures G.2.3.1 to G.2.3.3) by laying them out on a flat surface and then by folding or flaking them, and with just sufficient tension applied to remove wrinkles across the line of the measurement being taken (Figure G.2.3.4). The latter is especially important in spinnaker measurement, to avoid stretching the sail.

When checking sail leeches for not being convex it is vital to flake the sail, as shown in figure G.2.3.1 as this can change the leech from appearing convex to being concave. It is also important to flake the sail when measuring luff perpendiculars on full jibs see figure G.2.3.6.



Figures G.2.3.1 & G.2.3.2 *Leech flattening before and after flaking.*



Figure G.2.3.3 *Leech hollow before and after flaking.*

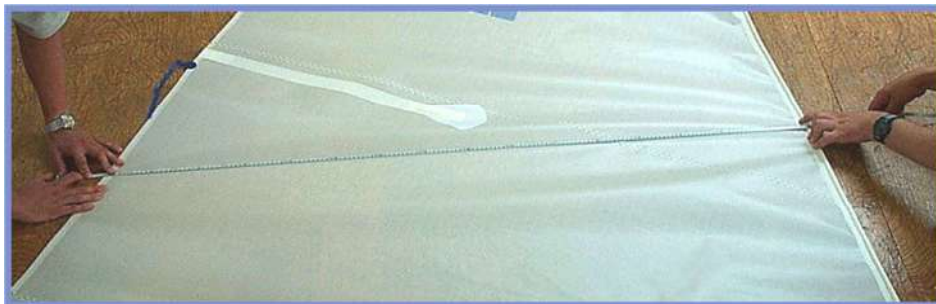

Figure G.2.3.4 *Proper tensioning of sail for wrinkle removal.*

All lengths shall be measured as the straight line distance as defined: for example, leech lengths between the head point and clew point (Figure G.2.3.2 on a headsail), spinnaker foot median between head point and mid foot point (Figure G.2.3.7). Corner reinforcements which cannot be "straightened" at the head of the spinnaker may necessitate the taking of two part measurements to an intermediate point, with the sum of these giving the dimension of the defined measurement (spinnaker foot median, Figure G.2.3.5).

The luff perpendicular shall be measured as the shortest straight line distance swung across the sail by a tape from the clew point to the luff as appropriate, including bolt rope if any (Figure G.2.3.6).



Figure G.2.3.5

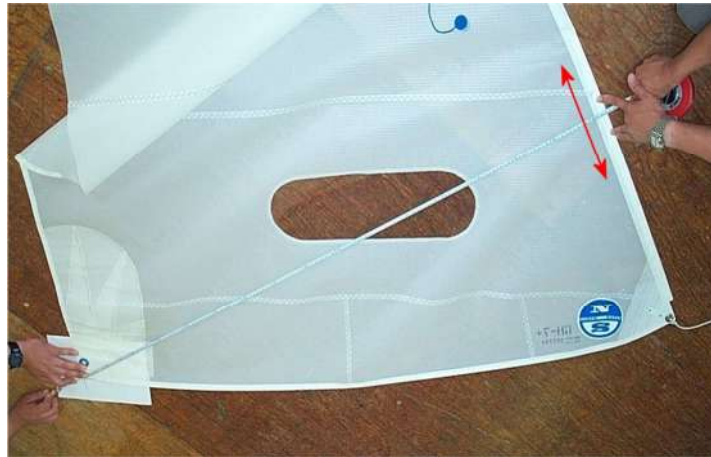

Figure G.2.3.6 *Luff perpendicular.*



Figure G.2.3.7 *Spinnaker foot median.*

Mainsail and headsail widths, except top width, shall be measured as the shortest straight line distance swung across the sail by a tape from the leech point to the luff including bolt rope if any (mainsail half width example in Figure G.2.3.8).



Figure K.3.2.4 *Sail width measurement with measurement tape*

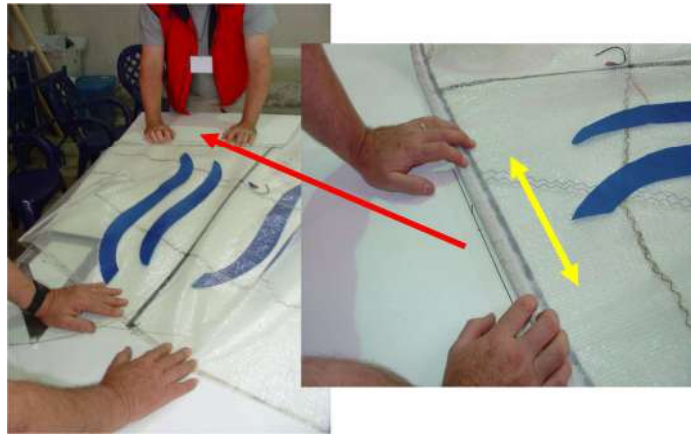

Figure K.3.2.4 *Sail width measurement on sail table with marks*

ERS H.5.2 states that when there is a sail edge hollow and a measurement point falls in the hollow;

- between adjacent batten pockets;
- between the aft head point and adjacent batten pocket;
- between the clew point and adjacent batten pocket
- between the tack point and adjacent batten pocket
- at an attachment;

the sail shall be flattened out in the area of the sail edge, the sail edge hollow shall be bridged by a straight line and the shortest distance "A" from the measurement point to the straight line shall be measured. This distance shall be added to the measurement being taken (Figure G.2.3.9).

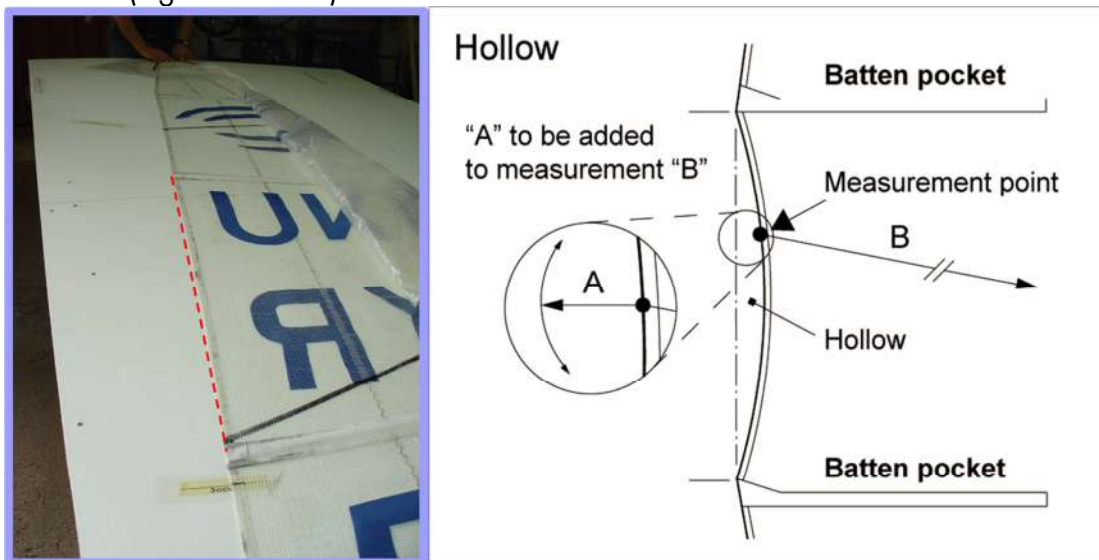

Figure G.2.3.9 *Bridging leech hollows.*

The spinnaker widths shall be measured as the straight line distance between the leech points as defined, for example the spinnaker half width in Figure G.2.3.10 is to be taken between the half luff point and the half leech point.



Figure G.2.3.10 *Spinnaker half width.*

G.2.4 Sail Table Preparation

Some Classes have ready-made Mylar or similar area check templates. The use of a Mylar sail template has the advantages of portability, consistency of measurement from event to event; ease of training volunteers and of providing a clean surface which can be quickly set up in the event of emergency measurement. They can be laid flat on the measuring surface, taped or pinned down and checked against the class rules for accuracy. If ready-made templates are not available, they can be created directly on the measuring surface. In that case, inspectors must ensure that they are allowed to write and put tape on top of the sail table and that the surface is stable. The Flying Dutchman class has a trailer, for transporting templates and measuring equipment, which on arrival folds out to become a sail measuring table.

Tables should have a reasonably flat clean surface, preferably melamine coated. Their size depends on their use: If only one table is available, then it should be large enough to accommodate the largest sail of the inventory either laid flat on top or, in case of a spinnaker, to match the longest dimension of the sail.

To have the best possible arrangement of the various marks on the table, a set of sails should be placed on the table to find the optimum position and above all to ensure that all sails will fit inside the table when placed on the marks! The mainsail head and clew areas and all three headsail corner areas have to be marked on the table, giving the approximate positions of the sails when placed for inspection. For the spinnaker, all measurement marks may be put in one line, near the edge of the table that is at least as long as the longest distance measurement specified in the class rules (usually that is the foot median). It is also important to check that it is possible to reach all parts of the sails when standing around the table edges: if not, assistants will be forced to get on top of the tables to reach a particular point and thus increase the time needed to inspect a sail.

Marks should be arranged in such a way that the sails will be laid down with the side for limitation stamping on top. For racing in trapezoid courses, limitation stamps are easier to see at the finish line if put on port tack clews.

If using one table for all sails (mainsail plus headsail -and spinnaker), color-coded marks for each type of sail will help the assistants recognize and pick the correct marks for each sail.

If the number of entries and thus the total number of sails to be inspected is considerable, and the sails are measured in the standard ERS way with half, quarter etc. leech points, an “automated” sail table with a grid system (Figure G.2.4.1) can help because it saves folding time to find leech points. For events with fewer entries or with ample time such as an Olympic regatta, grids are not necessary. Grids are not needed when the sails are measured with leech points at fixed radial distances from the head point (ERS upper point style, e.g. Finn or Dragon Class).

“Automated” Sail table example

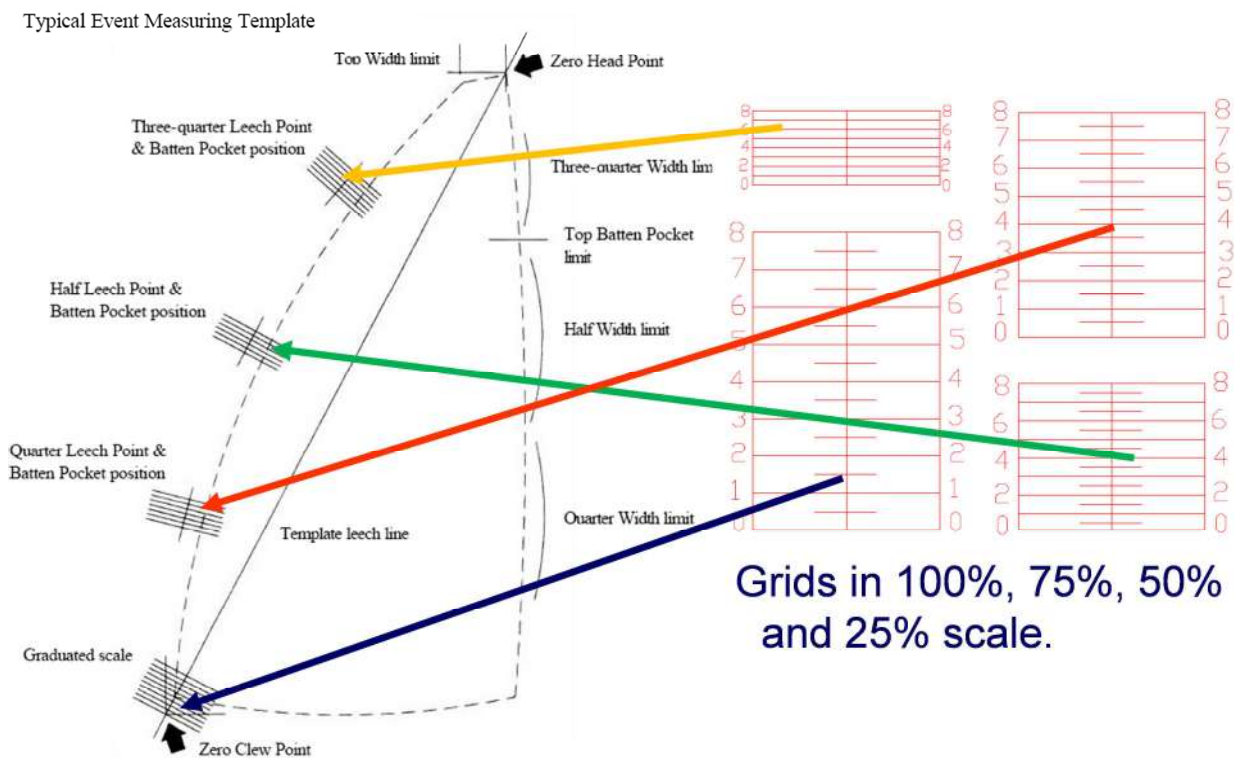

Figure G.2.4.1 “Automated” Sail table.

To set up a mainsail inspection table properly, it is important to start by laying a mainsail on the surface first, to decide on a position for the head point that keeps the clew point and the leech (when flaked) inside the table. The head point is the datum point for leech length measurement and also for the definition of the intermediate leech measurement points (half, quarter, three quarter and/or upper points) when the grid system is used instead of folding the sail as in certification measurement.

Once the head point and clew area have been decided as above, the head point is marked and a reference line is drawn from the head point to the clew, at least near the head, clew and around the mid-point of the maximum leech length distance (figure G.2.4.2). Points and lines should be made using thin pencil or marker pens, and the line is easier and more accurate to draw using a laser beam pointer and a batten as straight edge.

In addition to the datum (head point), limit marks for the top width and a square to help set the mainsail properly have to be drawn. The best solution is to use a rotating template that a top width gauge, with the pivot at the head point, fixed on the table with a small screw (Figure G.2.4.3). While the fixed square drawn on the table must be made at the

proper angle to keep the sail leech in line and flat when flaked, the rotating template will turn automatically to align the sail properly.

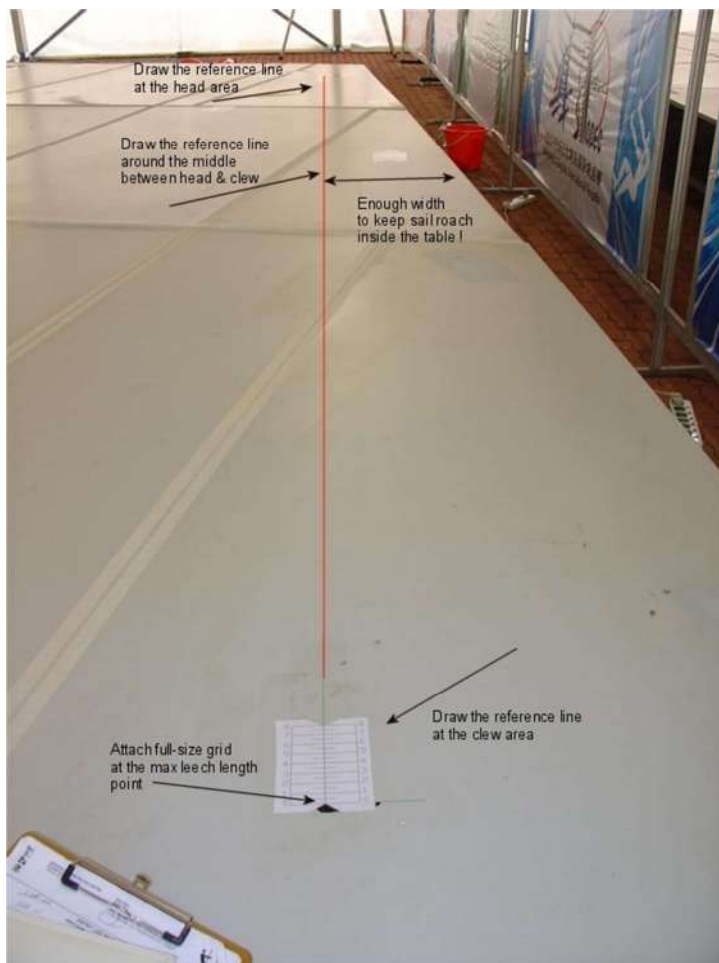

Figure G.2.4.2 *Leech length scale*

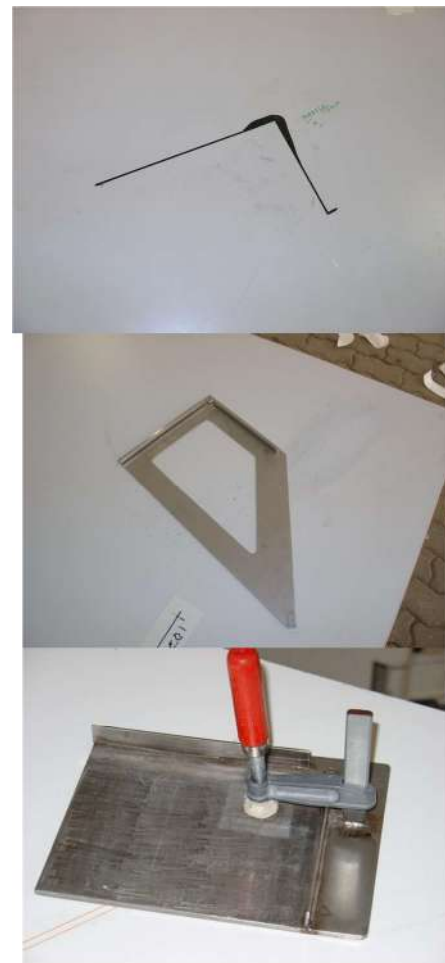

Figure G.2.4.3 *Head point jig*

For a table without a grid, only the maximum leech length point has to be marked on the reference line. In addition, if “upper point” style measurement points are defined in the class rules, short arcs with the defined radius should be drawn from the datum. When the sail is positioned on the table, these arcs will indicate the upper point positions on the leech.

If the grid system is to be used, then a set of grids have to be made, either drawn by hand directly on the table or printed on paper or transparency using a CAD program. In addition, a number of measurements have to be made on a number of sails, to find the amount of average roach expected at each measurement point. These numbers will indicate the approximate position of the grids in relation to the reference line for the half leech point, and then from the lines connecting the 50% scale grid to the head and clew points.

The 100% scale grid (Figure G.2.4.1) is positioned with its end at the maximum leech length point. Then, the exact middle point of the line between head and clew points is found, and then offset by the amount given as explained in the previous paragraph. This new offset “mid-point” is then joined with “new” reference lines from head and clew points as in Figure G.2.4.4: the offsets indicated there are valid only for a particular class and not standard universal numbers! The 50% grid is positioned at the offset mid-point, and the process is repeated for the two “new” reference lines, to find their middle points,

which when offset, will give the positions of the quarter and three quarter (Figure G.2.4.5) grids.

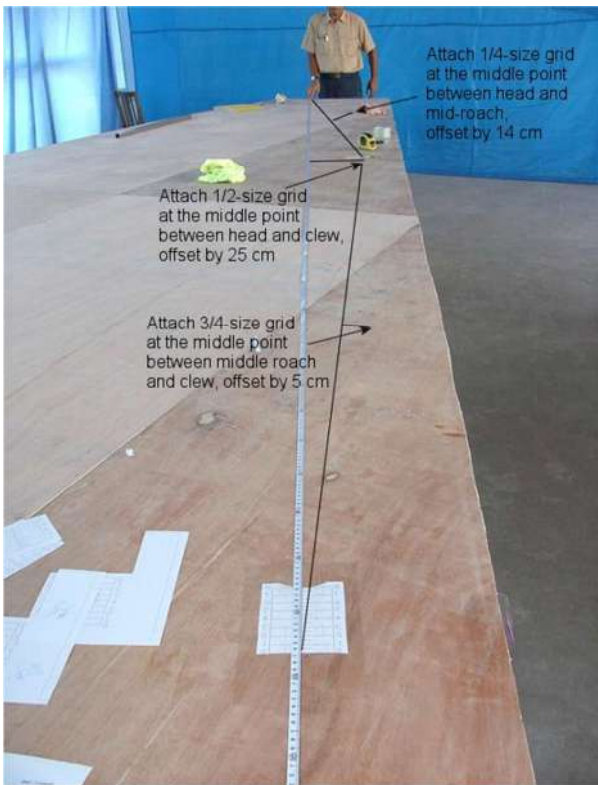

Figure G.2.4.4 *Leech point scales*

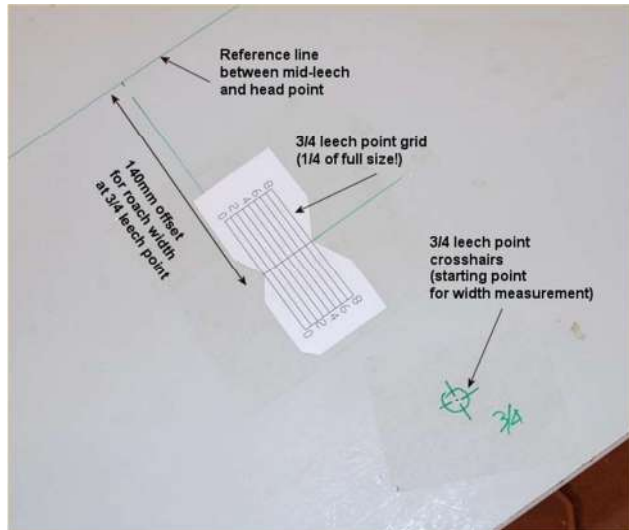

Figure G.2.4.5 *Three quarter point scale & width datum reference mark*

Having the half leech offset point as close to the actual sails leech, minimizes the (small) error that is introduced by the angle difference between the two “new” reference lines and the actual lines connecting the head, half leech and clew points on the sails. A small error is also introduced if the sail under inspection has a shorter leech than the maximum. In general, the error is small at the three quarter point, and given the scale of the grid, usually negligible. But in any case, when sails are found to be close to the limits, the position of the leech measurement point should be verified by folding.

The final step is to mark datum points for the sail widths, near the leech measurement points (Figure G.2.4.5), and their associated short arcs which define the width limits (Figure G.2.4.6). The other marks that may be needed are those for the batten pocket positions as in Figure G.2.4.6 for the inboard end of a full length top batten. All other items may be checked using specially marked measurement battens/rods, or templates for numbers etc. It is also helpful to attach a copy of the sail rules or a large sail plan diagram on a table corner for quick reference (Figure G.2.4.7).

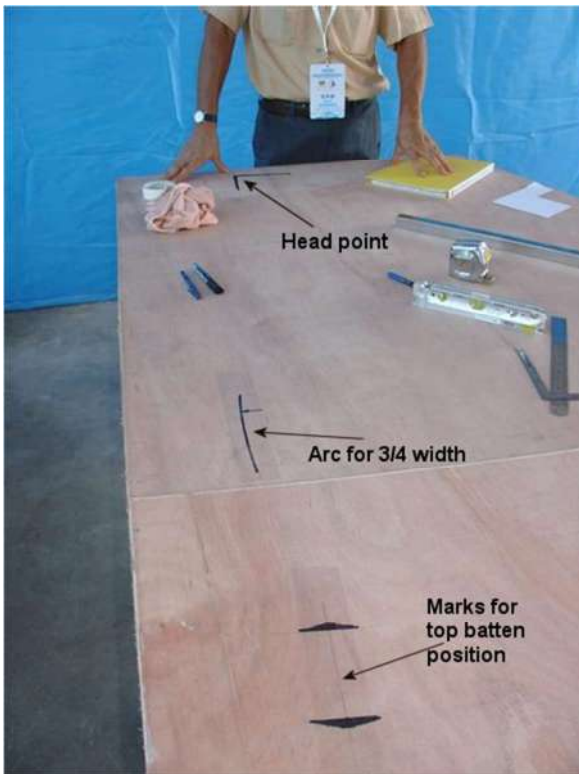

Figure G.2.4.6 Other measurement marks rules

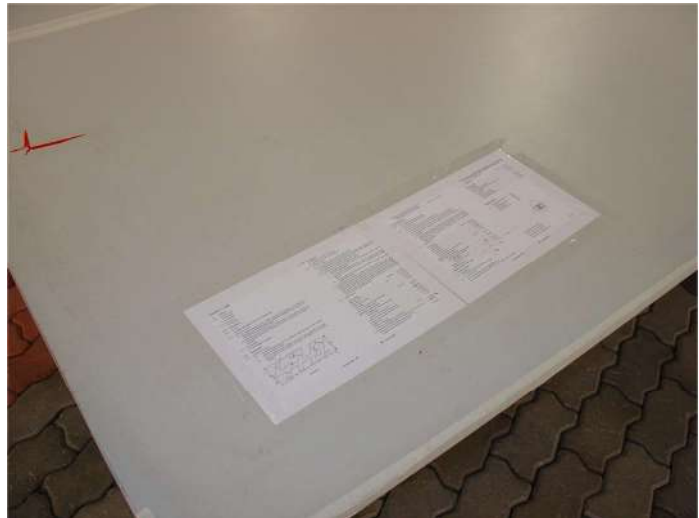

Figure G.2.4.7 Class Sail measurement

Headsails are easier to setup, as the head point is the datum for luff, leech and foot median lengths, so these should be marked with reference lines as in the case of the mainsail and maximum leech length. In addition, the foot length may be controlled with another reference line, and usually there is no need for a grid system: a jib foot may be folded easily to find the mid foot point.

Spinnakers may be checked using a grid system to find the leech measurement points, but everything may be done using a single reference line. The head point is again the datum and from that point a reference line is drawn down to the maximum foot median length. Then, the maximum leech length point is marked along with its half and $\frac{3}{4}$ points depending on class rules. The 100%, 50% and 25% scale grids are to be positioned at these points. Using the same datum point, the upper point, the limit for the foot median, and the various widths are marked on the line (Figure G.2.4.6). In this example, spinnaker marks are in red, headsail marks are blue and the mainsail marks are black. All marks should be covered with transparent tape for protection.

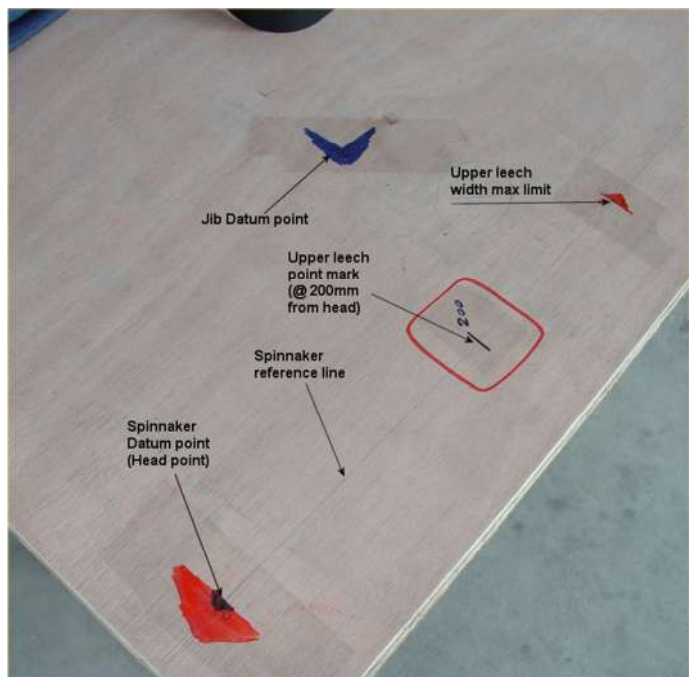

Figure G.2.4.8 Spinnaker measurement marks

G.3 Inspection techniques

Mainsails should be laid flat and flaked (Figure G.3.1) on the measuring template so that the head point is on the template's zero head point (Figure G.3.2) and the clew point is on the reference leech line in the area of the clew. Use the normal sail measurement batten to determine corner points if necessary. If there is a grid scale, the measurer should check the graduation upon which the clew point rests and mark the leech points on the sail at the corresponding leech graduations (marking the sail at the same numbers on all grids as the number the clew point rests on). Upper points should be marked on the sail directly from the table marks (Figure G.3.3).

Sail widths should be checked with the leech measurement point held at the respective datum point and the luff rotated (yellow arrow in Figure G.3.4). The limit which is indicated by the thin black line should be visible: if not, the sail should be checked with a tape measure.

Headsails are to be checked in the same way as above, but taking one measurement at a time. Spinnakers have to be laid on the table first with their leech and luff on the reference line, to mark all points, and then turned 90° to check widths on the same line. If the rules specify a foot median, the mid foot point may be found by folding.

Other measurements such as batten pockets, reinforcements, windows, sailmaker marks and sail numbers may be checked with measurement battens or special templates (Figure G.3.5).



Figure G.3.1 *Sail flaked on table*



Figure G.3.2 *Head positioned on jig*



Figure G.3.3 *Radial distance leech point mark*

G.4 Other Sail Dimensions (ERS G.8)

Other items to be measured include reinforcements, batten pockets, foot irregularity, seams and attachments.

Corner reinforcement size, whether primary or secondary, is measured from the corner measurement point, which may be outside the sail. The measurement is the greatest dimension from the corner measurement point to the outer edge of the reinforcement, and should be found by swinging an arc with the tape as illustrated in Figure G.4.1. Permitted tabling is not included in the measurement of reinforcement.

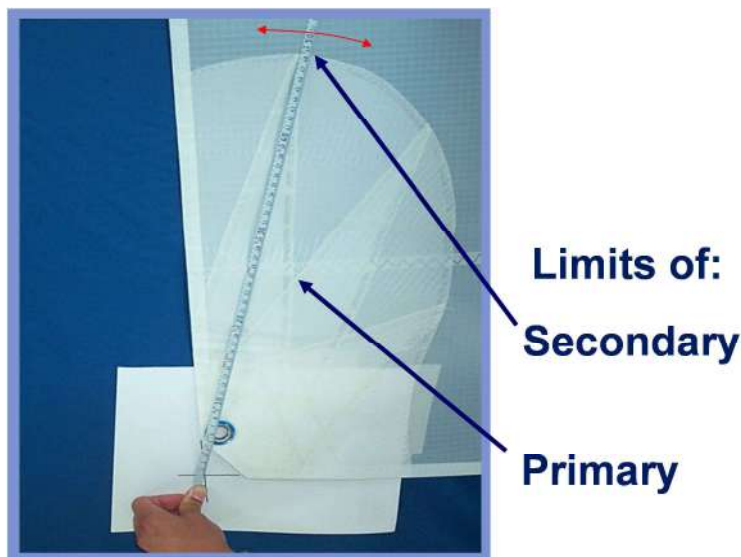

Figure G.4.1 *Corner reinforcement size.*

The measurement of any reinforcement, other than at one of the corners of the sail shall be taken to be the greatest dimension between any two points of the same reinforcement (Figure G.4.2 chafing patches, Figure G.4.3 batten pocket patches). This may not necessarily be continuous across the reinforcement.

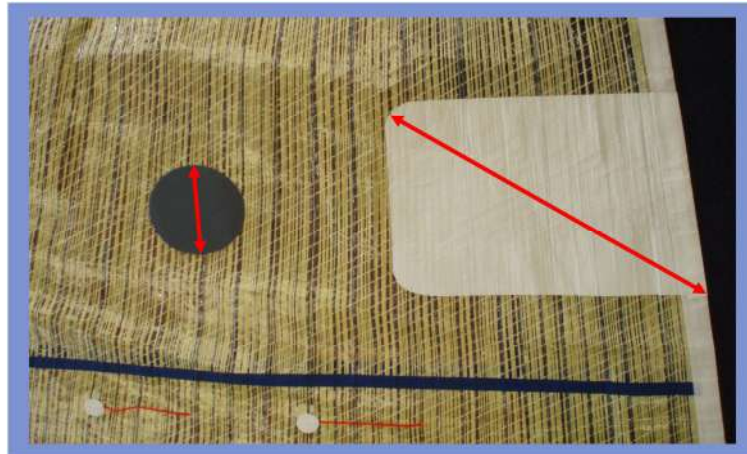

Figure G.4.2 *Chafing patch size.*



Figure G.4.3 *Batten pocket patch size.*

The inside and outside lengths of a batten pocket are measured ignoring the effect of any elastic or other batten retaining device.

The inside length is the greatest dimension measured parallel to the centreline of the pocket from the sail edge to the inside of the stitching, fold or similar at the inside end of the pocket. The outside length is the greatest dimension measured parallel to the centreline of the pocket, from the sail edge to the extreme end of the pocket material.

Local widening for batten insertion is not included in the measurement of either inside or outside batten pocket width.

The inside width is measured at 90° to the centreline of the pocket, between the inside of the stitching or similar on each side of the pocket. The outside width is measured at 90° to the centreline of the pocket, between the outside edges of the pocket material.

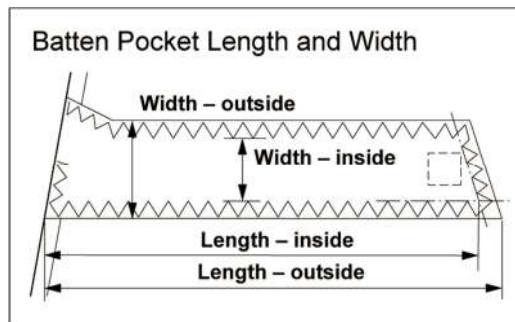

Figure G.4.4 *Batten pocket length and width measurement.*

To check the foot irregularity, with the sail flat in the area of the foot, the tack point should be folded over and run down the edge of the foot, and its extensions if necessary, until it reaches the clew point. During this procedure, the greatest dimensional difference between the two parts of the sail edge, measured at 90° to the edges, should be noted. The same procedure should be undertaken, folding over and running the clew point down the edge of the foot until it reaches the tack point. Again, the greatest dimensional difference between the sail edges should be noted. The foot irregularity is the greater of the two noted dimensions (figure G.4.5).

Foot irregularity used together with a foot median limitation can help control the shape and size of the foot roach in cases where a deck sweeper headsail design is used by a class: appropriate foot irregularity values can prevent drastic changes in curvature along the foot, and the foot median controls total size of the roach.

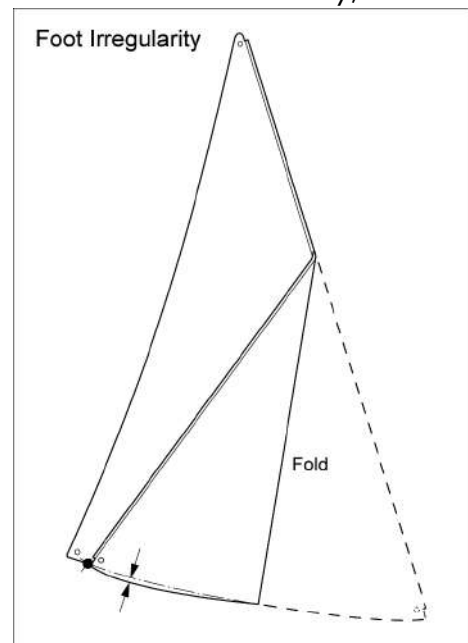

Figure G.4.5 *Foot irregularity.*

Additional Sail Controls

Additional sail controls include items such as the color of the sail (Figure G.4.7), additional symbols like a women's rhombus (Figure G.4.8), the sail construction (e.g. number of panels) and the presence of valid class royalty tags (stickers, buttons etc., Figure G.4.9).



Figure G.4.7



Figure G.4.8

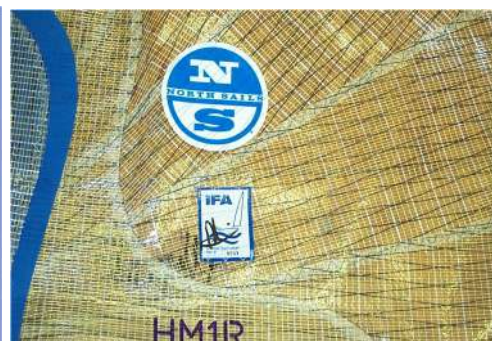

Figure G.4.9

G.5 Identification on Sails

Measurement requirements for the size, shape and position etc. of class insignia, national letters and sail numbers are laid down in RRS 77& RRS Appendix G, and in most individual class rules. These shall be checked when required to be so by class rules or an MNA. A number of classes specify that sail numbers shall be sequential and not re issued and in such cases the legality of such sail numbers should be checked.

Where there are differences between the RRS and class rules, the class rules shall prevail. Where class rules invoke the RRS then, except when altered by class rules, the RRS shall be applied.

RRS Appendix G – 1.1 specifies that:

“Every boat of a WS Class shall carry on her mainsail and, as provided in rules G1.3 (d) and G1.3 (e) for letters and numbers only, on her spinnaker and headsail:

- the insignia denoting her class;
- at all international events, except when the boats are provided to all competitors, national letters denoting her national authority from the table below. For the purposes of this rule, international events are WS events, world and continental championships, and events described as international events in their notices of race and sailing instructions; and
- a sail number of no more than four digits allotted by her national authority or, when so required by the class rules, by the international class association. The four-digit limitation does not apply to classes whose WS membership or recognition took effect before 1 April 1997. Alternatively, if permitted in the class rules, an owner may be allotted a personal sail number by the relevant issuing authority, which may be used on all his boats in that class.
- Sails measured before 31 March 1999 shall comply with rule G1.1 or with the rules applicable at the time of measurement.

RRS Appendix G.1.2(a) requires, amongst other things, the national letters and sail numbers to be "clearly legible". Determination of this requirement will be relative and is not strictly a matter of measurement but at least it should be taken to mean legible to the RC and Jury under adverse situations. It also specifies that acceptable typefaces are the sans-serif ones (Figure G.5.1)

Several classes specify the color of insignia, letters and numbers. Where this is not the case, the RRS Appendix G.1.2(a) rule should be applied. This requires the national letters and sail numbers (but not the insignia) to be of the same color.

RRS Appendix G.1.3 specifies the positioning of identification as follows:

- Except as provided in rules G.1.3 (d) and G.1.3 (e), class insignia, national letters and sail numbers shall when possible be wholly above an arc whose centre is the head point and whose radius is 60% of the leech length. They shall be placed at different heights on the two sides of the sail, those on the starboard side being uppermost.

- The class insignia shall be placed above the national letters. If the class insignia is of such a design that two of them coincide when placed back to back on both sides of the sail, they may be so placed.
- National letters shall be placed above the sail number.
- The national letters and sail number shall be displayed on the front side of a spinnaker but may be placed on both sides. They shall be displayed wholly below an arc whose centre is the head point and whose radius is 40% of the foot median and, when possible, wholly above an arc whose radius is 60% of the foot median.
- The national letters and sail number shall be displayed on both sides of a headsail whose clew can extend behind the mast 30% or more of the mainsail foot length. They shall be displayed wholly below an arc whose centre is the head point and whose radius is 50% of the luff length and, if possible, wholly above an arc whose radius is 75% of the luff length.



Figure G.5.1 *Identification on Sails: example of Sans-serif typeface.*

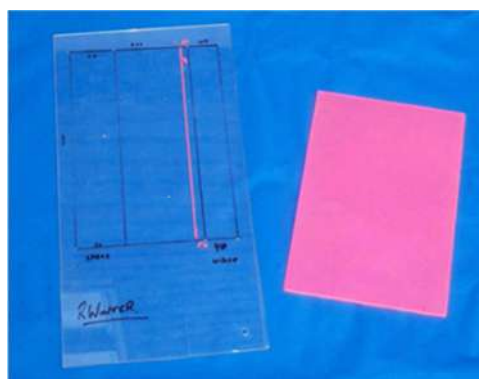

Figure G.5.2 *Sail number template*

G.6 Advertising on Sails

The size and position of permitted advertising on sails is governed by WS Regulation 20, except at events at which the International Olympic Charter applies, as in the Olympic Games.

Class rules and the rules of a Rating System may prohibit or limit the right to display Advertising on the boat. If the class rules or the rules of a System do not prohibit or limit the right to display Advertising, it shall be permitted. This does not apply for Olympic Classes, which cannot prohibit or limit in any way the right to display advertising while racing.

Personal Advertising on sails shall be clearly separated from national letters and sail numbers and from Class insignia unless it is part thereof.

Event advertising on sails is permitted only on windsurfers, on each side of the sail, placed between the sail numbers and the boom (wishbone) and aft of the foot median line. Such advertising shall not exceed 0.4 m².

Sailmaker's marks are permitted at all times as follows:

- i) Boats: One sailmaker's mark, which may include the name or mark of the sailcloth manufacturer and the pattern or model of the sail, may be displayed on both sides of any sail and shall fit within a 150mm x 150mm square. On sails, other than spinnakers, no part of such mark shall be placed farther from the tack point than the greater of 300mm or 15% of the length of the foot.
- ii) Sailboards: One sailmaker's mark, which may include the name or mark of the sailcloth manufacturer and the pattern or model of the sail, may be displayed on both sides of the sail and shall fit within a 150mm x 150mm square. No part of such mark shall be placed farther from the tack point than 20% of the foot length of the sail, including the mast sleeve. The mark may alternatively be displayed on the lower half of the part of the sail above the wishbone (boom) but no part of it shall be farther than 500mm from the clew point.

G.7 Certification marks on Sails

If specified in class rules, sails have to be certified before being presented for inspection. Inspectors need to be able to recognize the certification marks on sails, which usually take the form of a numbered sail button with the MNA logo (figure G.7.1), a sticker/label (figure G.7.2) or a stamp (figure G.7.3) with the details of the MNA and official measurer. In some cases the certification mark may be just a signature but classes should try to avoid this for their sails, as it is next to impossible to verify the identity -and the authority- of the person who signed the sail.

Certification marks should always include the date because this is the only way to check if a sail is eligible for grandfathering in case of a specific class rule that applies after a certain date.



Figure G.7.1 Sail button



Figure G.7.2 Sail certification stickers

Certification marks should be at the tack of jibs and mainsails leaving the clew area for event limitation marks / stamps.

SECTION H. MEASUREMENT PROTESTS

H.1 Introduction

Measurement protests are in most cases initiated as a result of post-race inspections. They are often the cause of much anxiety and emotion because of the inference that the owner or person in charge has knowledge, or should have had knowledge of the rules breach.

The entire process of a measurement protest is controlled by only a few basic rules. Competitors, race and protest committees, and measurers/inspectors are all required to abide by these rules.

H.2 Right to Protest

A Measurer / Equipment Inspector may discover issues on a boat that appear to breach the rules. Before the racing starts normally he will request the boat crew to correct any such situations. However after racing starts he has different responsibilities as a member of the event's Technical Committee. His role changes so that he initiates the process for the Technical Committee protests under rule 60.1. Measurement protests can also be initiated by another boat, or by the Race Committee, or by the protest committee. The rules do not give a Class Association or National Authority the right to protest on their own.

Usually, when an Equipment Inspector files a protest as part of the Technical Committee he has to prepare the protest; therefore it is essential that he understands the relevant parts of the RRS as, in the event of a measurement protest, the procedures given in the RRS must be followed correctly. RRS 60.4 deals with the requirements so a protest can be considered valid. Typically the Chairman of the Technical Committee will represent the Technical Committee during a protest; therefore he needs to know how to behave and how to support his case in front of the Jury.

H.3 Relevant Rules and other Documents

H.3.1 RR60.2 Intention to protest

- (a) If a *protest* concerns an incident observed by the protestor in the racing area:
 - If the protestor is a *committee*, it shall inform the boat after the race within the protest time limit of its intention to protest her.
 - (b) However, if
 - (1) the protestee is not within hailing distance at the time of the incident,
 - (2) the incident was an error in *sailing the course*,
 - (3) the incident was not observed by the protestor in the racing area, or
 - (4) a protest committee decides to protest a boat under RRS 60.4(c), then the only requirement for the protestor is to inform the protestee of its intention to protest at the first reasonable opportunity.
- (c) If at the time of the incident it is obvious to a protesting boat that a member of either crew is in danger, or that injury or serious damage has resulted, RRS 60.2(a) and 60.2(b) do not apply to her, but she shall attempt to inform the other boat within the protest time limit of her intention to protest.

- (d) A *committee* may inform a boat of its intention to protest by posting a notice on the official notice board.

H.3.2 RR60.3 Delivering a protest

- (a) When delivered, a *protest* shall be in writing and identify the protestor, the protestee, and the incident.
- (b) A *protest* shall be delivered to the race office (or by such other method as stated in the sailing instructions) within the protest time limit unless the protest committee decides there is good reason to extend the time. The protest time limit is:
- (1) for *protests* about an incident observed in the racing area, two hours after the last boat in the race *finishes*, or
 - (2) for other *protests*, two hours after the relevant information is available to the protestor.
- However, if the sailing instructions state a different protest time limit, then that time limit applies instead.

H.3.3 RR 60.4 Protest validity

RR 60.4 states that:

- (a) A *protest* is invalid
- (1) if it does not comply with the definition *Protest* or RRS 60.2 or 60.3,
 - (2) if it is from a boat that alleges a breach of a rule of Part 2 or RRS 31, but she was not involved in it or did not see the incident, or
 - (3) as far as it alleges a breach of RRS 69 or a Regulation referred to in RRS 6, unless permitted by the Regulation concerned.
- (b) A *protest* is invalid also if it is from a *committee* and is based on information from
- (1) a request for redress,
 - (2) an invalid *protest*, or
 - (3) a report from a person with a *conflict of interest* (other than a representative of the boat herself).
- (c) However, RRS 60.4(b) does not apply to a *protest* from
- (1) the protest committee if it learns of an incident involving a boat that may have resulted in injury or serious damage,
 - (2) the protest committee if it learns during the hearing of a valid *protest* that the boat, although not a *party* to the hearing, was involved in the incident and may have broken a *rule*, or
 - (3) the technical committee if it has first conducted an inspection and decided a boat or personal equipment does not comply with the class rules or RRS 50.

H.3.4 RR 78

RRS 78 states that:

78.1 While a boat is *racing*, her owner and any other person in charge shall ensure that the boat is maintained to comply with her class rules and that her measurement or rating certificate, if any, remains valid. In addition, the boat shall also comply at other times specified in the class rules, the notice of race or the sailing instructions. When a *rule* provides that the penalty for a breach of a class rule may be less than disqualification, the same penalty will apply to a breach of this rule.

78.2 When a *rule* requires a valid certificate to be produced or its existence verified before a boat *rac*es, and this cannot be done, the boat may *race* provided that the appropriate *committee* receives a statement signed by the person in charge that a valid certificate exists. The boat shall produce the certificate or arrange for its existence to be verified by the appropriate *committee* before the start of the last day of the event, or of the first series, whichever is earlier. The penalty for breaking this rule is disqualification without a hearing from all races of the event.

H.3.5 RR 60.5(d)

If the protest committee decides that a boat has broken a class rule:

(1) the boat shall not be penalized if any deviations in excess of tolerances specified in the class rules were caused by damage or normal wear and they did not improve the performance of the boat,

(2) the boat shall not race again until any such deviations have been corrected unless the protest committee decides there is, or has been, no reasonable opportunity to do so,

(3) any breach of the same rule in earlier races in the same event may have the same penalty imposed for all such races without further protest, and

(4) the boat may compete in subsequent races without changes to the boat, but only if she states in writing that she intends to appeal. If she fails to appeal, or the appeal is not successful, she shall be disqualified without a hearing from all subsequent races in which she competed.

It is a matter of judgement whether performance will have been improved but, for instance, a dinghy would normally not be disqualified if, through being dragged up a slipway, part of her keel band had a cross section less than that required by her class rules.

Likewise a protest committee would not be expected to disqualify a boat whose buoyancy equipment had been rendered ineffective by a collision for which she was not responsible.

H.3.6 RR 50 Competitor clothing and equipment

50.1

- (a) Competitors shall not wear or carry clothing or equipment for the purpose of increasing their weight.
- (b) Furthermore, a competitor's clothing and equipment shall not weigh more than 8 kilograms, excluding a crew harness (as defined in The Equipment Rules of Sailing) and clothing (including footwear) worn only below the knee. Class rules or the notice of race may specify a lower weight or a higher weight up to 10 kilograms. Class rules may include footwear and other clothing worn below the knee within that weight. A crew harness shall have positive buoyancy in fresh water and shall not weigh more than 2 kilograms, except that class rules may specify a higher weight up to 4 kilograms. Weights shall be determined as required by Appendix H.
- (c) A crew harness shall allow the competitor, at any time, to easily disconnect the harness from the trapeze or attachment to the boat.

50.2 Rules 50.1(b) and 50.1(c) do not apply to boats required to be equipped with lifelines.

When checking for clothing and equipment according to Appendix H, inspectors should be aware that if a sailor is found to have a piece of equipment for the sole purpose of increasing their weight, for example a lead belt, it will be a gross breach of RRS 2 and then require a report to the protest committee.

H.3.7 RR 69 Misconduct

Action or the promotion of action under RRS 69 is a very serious matter and should only be entered into after due consideration of all the factors involved in the alleged gross misconduct. To date there have only been two types of incidents where such action has been undertaken involving measurement or a measurer.

The first was where an equipment inspector, whilst carrying out his duties, was verbally abused by a competitor. In such a case only the measurer can judge the degree of abuse and whether or not this warrants promotion of action under this rule.

The second was where there was an undisputed case of either measurement cheating or fraudulent certification marking. In such cases, provided that there is no doubt whatsoever, the measurer should not hesitate to make a report to the race committee that could prompt the protest committee or international jury to initiate action under RRS 69.

In any case when filling out a report to the race committee that involves cheating or verbal abuse the measurer or equipment inspector should always list RRS 2 among the rules breached.

SECTION I. ACCURACY, PRECISION & REPRODUCIBILITY OF MEASUREMENTS.

I.1 Introduction

In order for measurements to be meaningful they must be accurate, precise and reproducible so that they can be repeated by another measurer at another time with similar results. There are two main elements that affect accuracy of measurement - measurers' errors and the accuracy of the equipment used.

Measurers' errors can result from misinterpreting the rules thus measuring in the wrong way to the wrong points, from miss-reading a measurement, incorrectly using measurement equipment, or as a result of incorrect recording of the data.

To avoid misinterpreting the rules the measurer must be completely conversant with the class rules and the ERS if applicable. It also helps to occasionally measure with other class measurers, at a regatta, or attend a measurement seminar to ensure that your understanding of the rules is correct. If in any doubt, contact the relevant authority for guidance.

To reduce the chances of misreading, especially if you get a deviant reading, measure twice or get someone else to re measure whenever possible, do not rush, do not measure when tired, take breaks if measuring for a long time

Techniques for using measurement equipment correctly and precisely are covered in the next few sections, and some typical causes of error are described below.

I.2 Basic Standards and Units

Measurement

A measurement is the comparison of the quantity to be determined with a standard, and is therefore a ratio plus a unit. For accurate, precise and reproducible results the measured parameter must be precisely defined and prescriptions given for the measurement tools and procedures.

Units

The Standard International (SI), i.e. metric units should be used for sailboat measurement, unless specified in the class rules. The units must be clearly stated together with the numerical value, for a measurement to be meaningful.

Basic quantities

Table H.2.1 Fundamental quantities

Fundamental quantities	Units	Derived quantities
Length	Meter (m)	area (m ²), volume (m ³)
Time	second (s)	period (s), frequency (Hz)
Mass	kilogram (kg)	weight (N), density (kg/m ³), moment of inertia (kg·m ²)

All other mechanical quantities can be expressed in terms of these three basic quantities.

1.3 Definition of terms

Accurate and precise measurement requires:

- 1) Precise definition of the quantity to be measured.
- 2) Calibrated instruments, to ensure accuracy.
- 3) Correct procedures, designed to optimize precision and reproducibility.
- 4) Appropriate measurement facilities and conditions.
- 5) Careful record keeping and immediate comparison with the mandated value.

In daily conversation a number of terms are often loosely and imprecisely used, so some relevant terms will now be defined:

True value:

Mean of an infinite number of accurate measurements, an unattainable ideal. The average of the measurements is a best estimate of the true value and probably within the standard deviation of the mean of the true value. For practical purposes, when discussing with the jury, the finally found value can be declared to be accurate and within the precision of the true value.

Error:

The error, or deviation, is the difference between the measured value and the true value, but as we cannot know the true value the error has to be estimated from a series of measurements and theory.

The following types of errors are generally under the control of the measurer and can be minimized by appropriate methodology and equipment. These are errors, in the sense that they are mistakes, which should be corrected:

- 1) Mistakes in recording or calculating results
- 2) Reproducibility, determined by methodology and stability
- 3) Round-off errors, due to poor calculation practices
- 4) Quantization, due to insufficient resolution of the measuring instrument
- 5) Incorrect measurement, e.g. LOA parallel to the deck rather than the baseline.

That leaves two primary sources of error in the sense that they are deviations from the true value:

- 6) Systematic errors, which determine accuracy
- 7) Random errors, which determine precision

Accuracy:

How close the measurement is to the true value. It is a measure of the correctness of the result and is determined by the systematic errors. The use of an improperly calibrated instrument leads to inaccurate measurement, which can however be very reproducible and precise. Accuracy is determined by how well the systematic errors are treated.

Precision:

Precision is the extent to which a given set of measurements of the same quantity agree with their mean and is characterized by the scatter of successive measurements. A

qualitative estimate of the precision is obtained by asking “how much would a second measurement differ from the first one?” Many calculators will give you the “standard deviation”, which is a measure of the precision for a large set of readings. Precision also depends on the resolution of the measurement device. A measurement can be extremely precise, but not necessarily be accurate.

Reproducibility:

Reproducibility is defined as the closeness of the agreement between the results of measurements of the same quantity carried out under *changed* conditions or at different locations or times. Lack of reproducibility can be due to either systematic or random errors, different measurement tools or protocols.

Round-off error:

This is the error in a calculation or measurement due to using only a finite number of significant digits to represent the data. With modern calculators, which typically use 9 digits, calculator round-off errors are insignificant with respect to the random errors of measurement, but the input data must have sufficient significant figures. For example $3 \times 1/3 \approx 3 \times 0.33 = 0.99!$

Significant figures:

The number of digits, including trailing zeros, used to specify a measurement. For digital instruments such as electronic scales, micrometers and watches this is the number of digits displayed. Measurements, and the results, of calculations should only be quoted to the precision of the measurement.

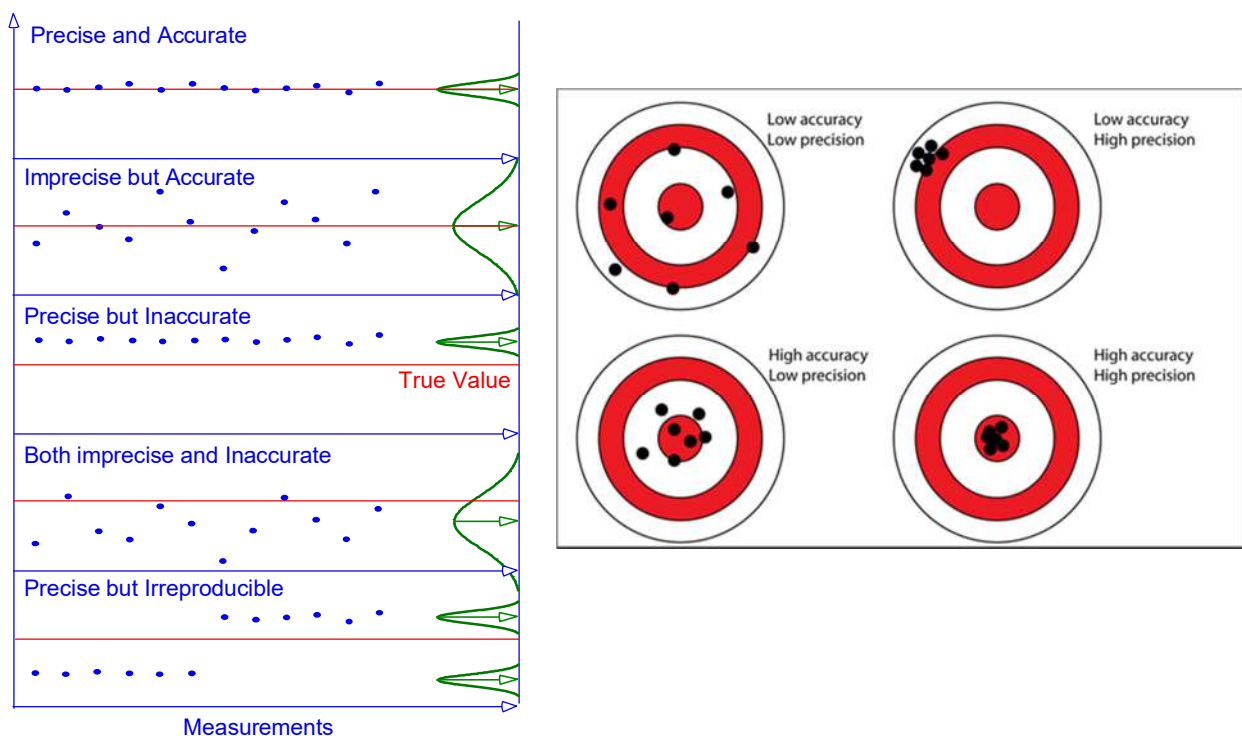

Figure 1.3.1 Histograms of the scatter of many measurements of the same quantity illustrating the difference between accuracy, precision and reproducibility.

1.4 Errors

Systematic errors

These are errors which are reproducible from measurement to measurement and caused by:

- Incorrect calibration or conditions of use.
- Imprecise definition of the quantity to be measured.
- Faulty methods or procedures.
- Defective or inappropriate instruments.
- Incomplete or approximate equations.
- Bias on the part of the measurer.

Properties:

- Cannot be reduced by averaging, as any given systematic error is reproducible and of constant sign.
- Systematic errors Δ add algebraically, $\Delta = \Sigma \cdot \Delta_i$.
- Can be corrected later if recognized.
- They determine the accuracy of the measurement.

Examples of systematic errors:

- End hooks or damage on end of measuring tapes or rulers. These can be eliminated by using the 10 cm mark instead of the zero.
- Tension and elasticity of measuring tapes (use only calibrated steel tapes, not woven tapes).
- Stretching and distortion of templates (use Mylar for sail templates and master drawings, not paper).
- Expansion due to temperature. Measuring an aluminium mast with a steel tape under a hot sun for instance.
- Incorrect calibration of scales. Zero offset, or tare, and scale factor.
- Nonlinear response of scales. High precision scales require multi point calibration.

Measurement Tape Errors

Off the shelf Class II steel measurement tapes are surprisingly good and can be used for measurement but preferably after comparison with a certified class I tape to confirm their calibration. Every IM should have one class I measurement tape as a reference but generally use cheaper class II commercial tapes for measuring.

End error

If the end of the tape or rule is damaged there may be an error in the measurement. It is good practice to check that the length of the tape or rule over its first 100 mm is correct. Some measuring tapes have sliding hooks at their end, to facilitate inside and outside measurements, which are legal for all classes, but create an additional value to the certification error. Precision tapes have their zero offset from the end of the tape. A bent tape (by stepping on it) will also give wrong dimensions.

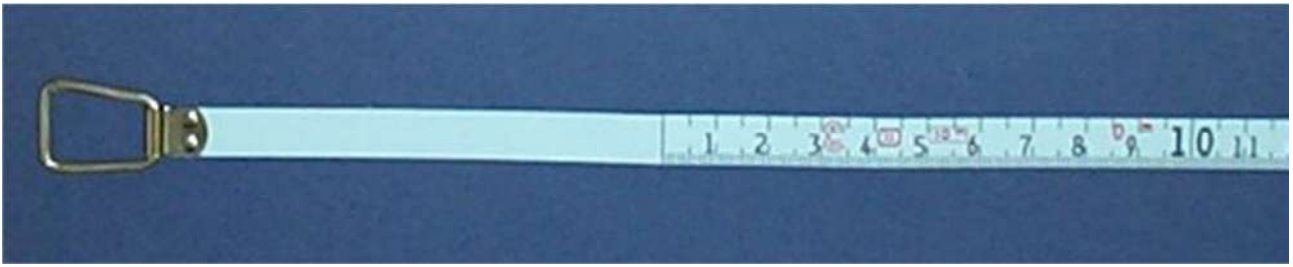

Figure I.4.1 A measuring tape with an offset zero to eliminate end errors.

Temperature errors

Measuring tapes, as well as the items to be measured, expand as they get hotter, but unless made of the same material they expand at different rates. Steel has a coefficient of expansion $C_s = 11.6 \times 10^{-6}/^{\circ}\text{C}$, while the coefficient of expansion of aluminium is $C_{Al} = 23.4 \times 10^{-6}/^{\circ}\text{C}$.

Some coefficients of expansion are given in table I.4.2:

Table I.4.2 Thermal Expansion Coefficients

Material	Coefficient x $10^{-6}/\text{deg C}$
Aluminium (6061)	23.4
Brass	18.7
Copper	16.6
Stainless Steel (316)	16
Steel	11.6
Cast Iron	10.5
Polyester-Glass	25 (resin dependent)
PVC	50.4
Lead	29.3

The thermal expansion of wood and plywood depends on the grain direction and humidity but is typically $5 \times 10^{-6}/^{\circ}\text{C}$. For all combinations of fibres and resins, glass, carbon etc. the coefficients depend on the type of resin and fibres and the direction of the fibres. In most cases these are more or less unknown, so in important cases where there is doubt, try to measure in the morning or evening, when the temperature is close to 20°C .

For example if a 10m long mast is measured while it is in the sun both it and the tape measure can easily reach a temperature of 40°C . The change in length of a tape measure for a deviation in temperature $\Delta T = 20$ degrees C would be $\Delta L = L(\text{mm}) \times \Delta T(\text{deg. C}) \times C_s = 2.3 \text{ mm}$ while that of the mast would be 4.7 mm, i.e. the mast would appear to be 2.4 mm too long. The error can be reduced by carrying out the measurement in the shade when, for most practical purposes, the effect of temperature can be ignored.

Proper Tension

Most precision steel measuring tapes are calibrated at a temperature of 20°C with a tension of 49.0 N (5kg) applied, and in the absence of a tension being stated on the tape these values should be used for accurate measurement. However, unless supported, the sag can also contribute, see below. Cloth or plastic tapes should not be used for boat measurement.

1.5 Measurement Techniques and Reproducibility

Technique:

- (i) When possible, do not measure a quantity as the difference between two values, e.g. skin thickness, large tare weight, etc.
- (ii) The use of two scales (or tongue weight) is to be discouraged, except when the scale is a multi-pad scale specifically designed for this.

Use of precise templates:

Precision templates are often used in order to increase the precision and reproducibility of measurement checks especially during regatta inspection.

- Aluminium hull templates.
- Mylar master to check templates.
- Rudder and centreboard templates.
- Gunwale, rubbing strake gauges.
- Gauges for masts, booms and spinnaker poles.
- Mylar templates for sails.

Record keeping:

Accurate and complete records are essential during measurement and it is often beneficial to have a record keeper keep them while you measure. This facilitates

- Comparison with measurement certificate.
- Record keeping on paper as backup, as well as on a computer.
- Records should be available to measurers on the Internet.

Calibration of tools:

The calibration of all tools should ideally be checked before any important regatta.

- For sailboat measurement SI units and standards are used.
- For the precision required for sailboat measurement the calibration of steel tapes, callipers, etc. are generally not a problem.
- Calibration of weighing scales should, if possible be checked on site against calibration standards of similar mass to the object to be weighed.

1.6 Mass and Weight

The amount of matter an object contains is its mass "**m**". The mass of an object determines its inertia, that is, how difficult it is to get it to change its motion. Newton's second law is $\mathbf{F} = m\mathbf{a}$, or if a given force **F** is applied to the object then the bigger the mass **m** the smaller the acceleration **a** that results. The weight $\mathbf{W} = m\mathbf{g}$ of an object is the attractive force **W** that the earth exerts on the object and is proportional to the mass **m**. The proportionality constant "**g**" is the weight force per unit mass, in Newtons per kg, and varies with location.

Weighing an object actually measures the upward force **N** exerted by the scale on the object which is required to balance the downward weight force **W**. This upward force only equals the weight if the object is not accelerating and if these are the only two vertical forces acting.

The act of weighing measures the force **N** the scale exerts to balance the force of gravity on the object, however, scales are calibrated to read "the mass **m'** on which the gravitational force would be the same as that measured" rather than the force **N** which is actually measured, and therein lies the problem. That is, the scale manufacturer builds in the equation $m' = N/g$, and assumes a local value of "**g**". Thus when a scale is moved (from one latitude to another, so "**g**" changes) the scale calibration is no longer valid. For accurate weighing the scales must be calibrated (span adjusted) in the location in which they are to be used.

World Sailing
Office 401, 4th Floor
3 Shortlands
London
W6 8DA
United Kingdom

www.sailing.org

sport / nature / technology



World
Sailing